

CONCRETE BLOCK PAVING

Book 3 – Specification and Installation

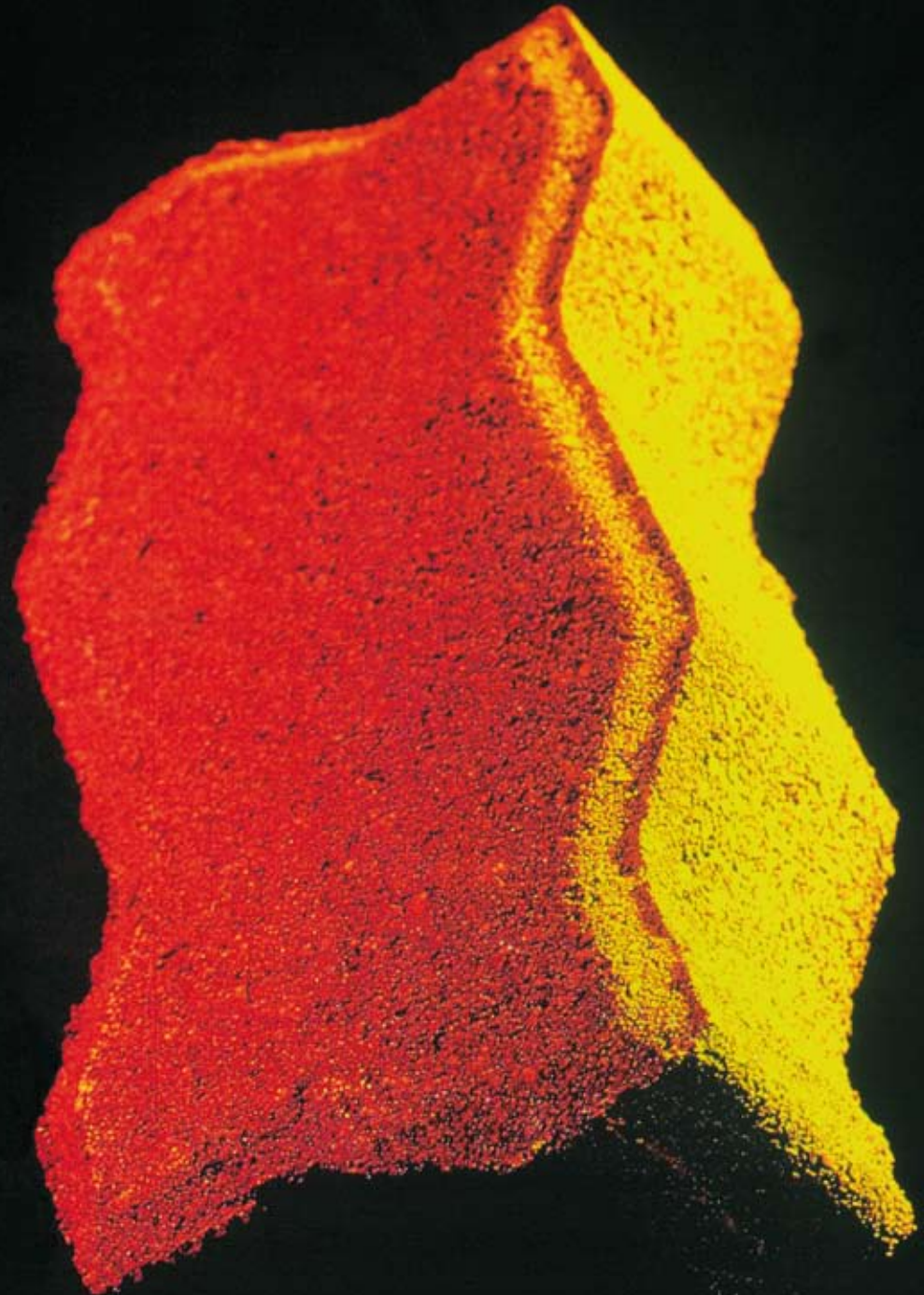

*A walk-over in cost, looks and
durability for Concrete Block Paving*

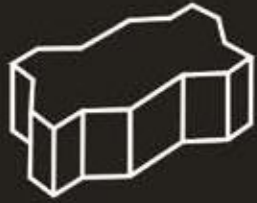



Concrete Block Paving

Book 3: Specification and Installation

Published by the Concrete Manufacturers Association

Block D, Lone Creek, Waterfall Office Park, Bekker Road, Midrand

PO Box 168 Halfway House 1685

Telephone +27 11 805 6742

Fax +27 86 524 9216

e-mail main.cma@gmail.com

Web Site: <http://www.cma.org.za>

Fifth edition 2009

CONTENTS

PREFACE	2
EXTRACTS FROM SANS1200 MJ – 1984 AND COMMENTARY	2
3. MATERIALS	2
3.1 UNITS	2
3.2 KERBS AND CHANNELS	5
3.3 SAND FOR BEDDING AND JOINTING	5
4. PLANT	6
4.1 GENERAL	6
4.2 ROLLER	6
4.3 MECHANICAL COMPACTOR	6
5. CONSTRUCTION	6
5.1 PREPARATION	6
5.2 EDGE RESTRAINTS	7
5.3 PLACING AND COMPACTING OF SAND BED	7
5.4 LAYING OF UNITS	8
5.5 FILLING GAPS IN UNIT PATTERN	8
5.6 COMPACTION OF UNITS	9
5.7 JOINT FILLING	9
6. TOLERANCES	9
6.1 GENERAL	9
6.2 PERMISSIBLE DEVIATIONS	10
7. TESTING	10
7.1 GENERAL	10
7.2 TRIAL SECTION	11
7.3 SUBBASE, FORMATION AND OTHER FOUNDATION LAYERS	11
7.4 BLOCKS	11
7.5 CONCRETE FOR GAP FILLING	11
7.6 KERBS, CHANNELS AND OTHER DEVICES	11
7.7 PONDING	11
DETAILS OF CONCRETE BLOCK PAVING	12
<i>NOTE: Use of Computer Aided Design (CAD). The following details in this manual are available on CD Rom in Caddie. Auto CAD and DXF format.</i>	
<i>Please contact the Concrete Manufacturers Association if you require these formats.</i>	
■ PATTERNS — GENERAL	12
■ PATTERNS — ADAPTATION OF PATTERNS TO CHANGES IN ALIGNMENT	13
■ PATTERNS — DETAILS AT EDGE RESTRAINTS	14
■ PATTERNS — BLOCK TIE-IN TO BITUMEN SURFACES	15
■ PATTERNS — CUT JOINT AT CHANGE IN PATTERN ORIENTATION	16
■ PATTERNS — BLOCK ORIENTATION THROUGH CURVES	17
■ CONCRETE SLAB DETAILS DRAINAGE OF BEDDING SAND LAYER	18
■ CONCRETE SLAB DETAILS	19–21
■ PENETRATIONS	22
■ STEEP SLOPES	23
■ SURFACE DRAINAGE DETAILS	24
■ EDGE RESTRAINTS FOOTPATHS	25
■ EDGE RESTRAINTS LIGHT TRAFFIC	26
■ EDGE RESTRAINTS HEAVY TRAFFIC	27
■ EDGE RESTRAINTS USING PAVERS	28



PREFACE

The quality of paving depends on the care taken in all aspects of construction from subgrade preparation, to laying of paving blocks and final compaction. Good segmented paving depends just as much on good construction as on good blocks and design. Requirements for quality of blocks is given in SANS 1058 Concrete paving blocks, while SANS 1200 MJ is the standardised specification for civil engineering construction of segmented paving.

This book is intended for assisting in the preparation of construction specifications for paving roads, industrial hardstanding, and other areas with concrete paving blocks laid on a sand bed, the joints between the units being filled with jointing sand. It provides extracts from SANS 1200 MJ with accompanying commentary where appropriate. The clauses are typical of those, which should be incorporated in a contract specification, while the commentary gives background information to be considered in formulating them. Reference is also made to the Concrete Manufacturers Association Paving Manual Books 2 and 4

EXTRACTS FROM SANS1200 MJ – 1984 AND COMMENTARY

COMMENTARY NOTE: Text shown in italics refers to work, which is the responsibility of the earthworks contractor and not the paviour

3 MATERIALS

3.1 UNITS

3.1.1 GENERAL

The units as supplied shall be free from cracks that detract from their general appearance. At the point of manufacture no unit shall have any chip of dimension exceeding 15 mm or covering more than 3% of the periphery of the surface that is intended to be exposed. No units shall have any protuberance of height exceeding 3 mm.

The surface texture and colour of the units shall fall within the range of texture and colour represented by the manufacturer's approved samples. The colour shall penetrate to a depth of at least 5 mm below the wearing surface of each unit and the coloured layer shall be integrally bound to the body of the unit.

COMMENTARY

Colour Various block manufacturers use trade names to describe the colour of their blocks. Basic pigment colours are black, brown, red and tan. Reference samples showing range of colours agreed upon should be kept by purchaser. Non-pigmented blocks also may vary in colour due to cement and aggregate colour variation.

Texture The texture of blocks varies, depending on the manufacturing operation and the materials used. Smoother blocks are aesthetically more pleasing while rougher blocks provide better skid resistance. The texture should be consistent and reference samples approved.

3.1.2 CLASS, STRENGTH AND TYPE

Except when the blocks are:

- required for paving subject to wheel loads exceeding 30kN (see 5.6.2) or
- required in terms of the project specification to be of class 35 and are so scheduled; or
- required to comply with both a) and b) above, the blocks used shall be Class 25.

Class 25 blocks when tested in accordance with 7.4.1, shall have an average wet strength of at least 25 MPa. Blocks shall be of the type (S-A, S-B or S-C) scheduled or given on the drawings or required in terms of the project specification, as applicable, and shall comply with the relevant requirements of SANS 1058.

COMMENTARY

The specifier must decide on the type, class and thickness of paving block. The following is a guide to these characteristics:

Type: Type refers to the plan shape of the block whether interlocking (types S-A & S-B) or non-interlocking (S-C).

Block type S-A allows geometrical interlock between all faces of adjacent blocks. When keyed together these blocks resist the spread of joints by their plan geometry. Generally, these blocks can be laid in herringbone pattern parallel to both the longitudinal and transverse axes of the joints. Block type S-A is used in roads and heavy-duty pavements.

Block type S-B allows geometrical interlock between some faces of adjacent blocks which, when keyed together, resist the spread of joints parallel to the longitudinal axes of the blocks.

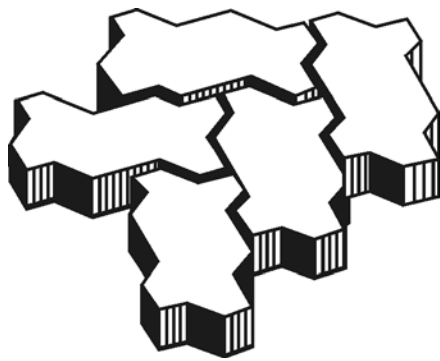

Block type S-A

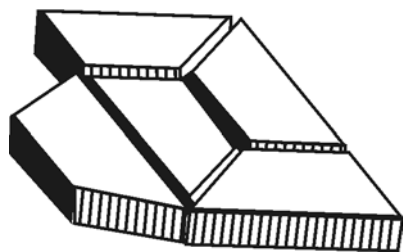
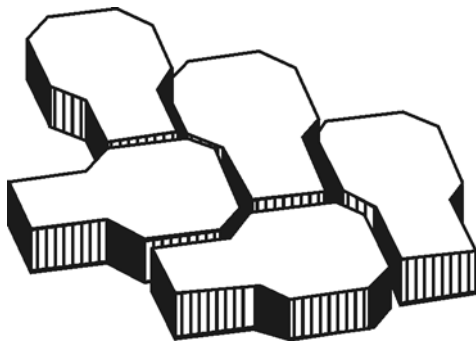

Block type S-B

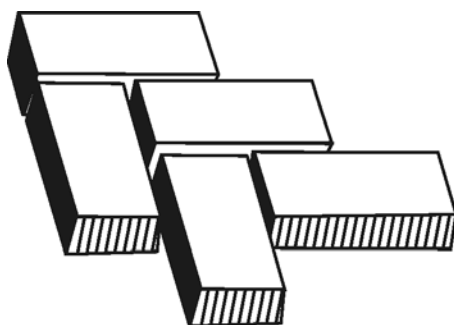

Block type S-C

Block type S-C allows no geometrical interlock between adjacent faces and relies on its dimensional accuracy and the accuracy of laying to develop interlock.

Class: Two classes i.e. compressive strengths are specified.

Class 25 has an average compressive strength of at least 25 MPa. Research has shown that the structural performance of the pavement is dependent on the degree of interlock, which spreads the load and is virtually independent of the strength of paving blocks, provided it is above a certain minimum level.

Class 25 blocks should be specified for most uses. The specifying of an unnecessarily high class will only increase the cost of paving without improving its performance.

Class 35 has an average compressive strength of at least 35 MPa and should be specified where exceptional loads may be encountered or where severe service or environmental conditions are known to exist or are expected.

It is important to note that the strength as required by SANS 1058 is based on day of despatch and not 28 day strength.

Extract from SANS 1058-1985

Table 1 Compressive strength of blocks

1	2	3
Class of block	Compressive strength, MPa, min	
	Average	Individual
25	25	20
35	35	30

The compressive strength test details are stated in SANS 1058. Blocks are immersed in water for a period of 24 ± 1 h, tested between 3mm thick plywood sheets and the compressive strength is calculated on the wearing surface of the blocks i.e. the area of block between chamfers provided that the wearing face area is 65% or more of the bed face area.

Blocks of 50,55,60 and 80 mm thickness are readily available ex stock. The thickness of the block to be used should be based on site conditions, design requirements and cost. The specifying of unnecessarily thick blocks will only increase cost without improving service performance.



COMMON KERB & CHANNEL SECTIONS

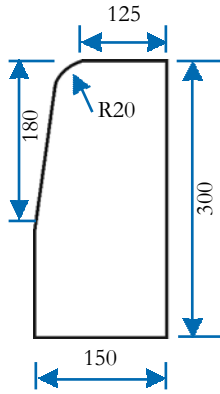

Fig. 3
Half-battered

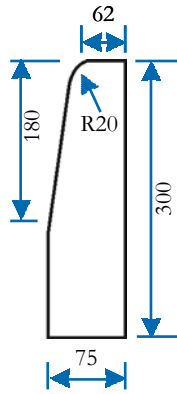

Fig. 5 (a)
Half-battered

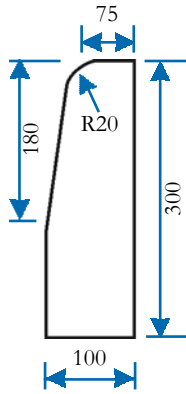

Fig. 5 (b)
Half-battered

KERBS

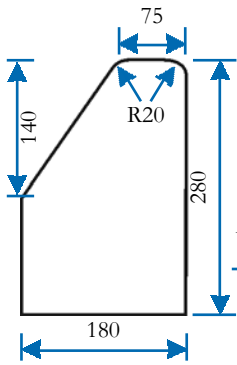

Fig. 7
Mountable

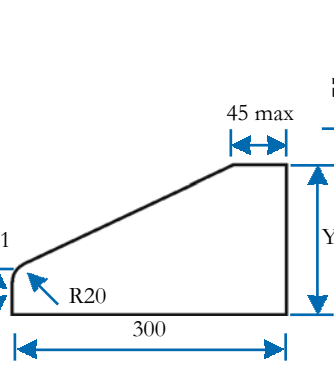

Fig. 8 (a)-(d)
Mountable

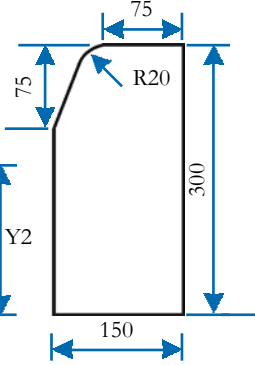

Fig. 9
Mountable

Size	Y1	Y2
a	50	150
b	75	175
c	100	200
d	125	225

EDGINGS

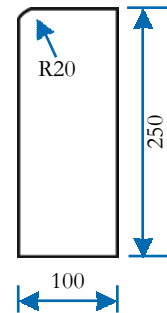

Fig. 10
Rectangular

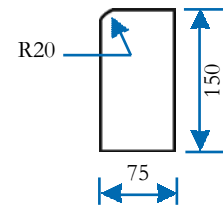

Fig. 11
Rectangular

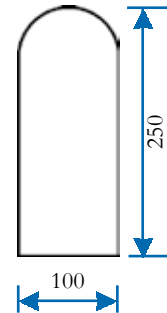

Fig. 12
Half-round

CHANNELS

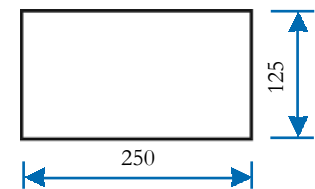

Fig. 13
Rectangular

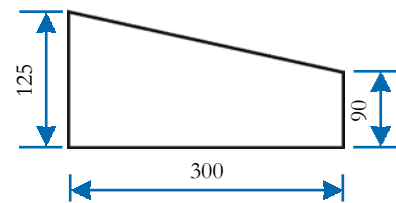

Fig. 14
Tapered

3.2 KERBS AND CHANNELS

Kerbs and channels shall be of the sections shown on the drawings (see opposite page) and shall comply with the relevant requirements of SANS 927 and, when applicable, SANS 1200 MK.

3.3 SAND FOR BEDDING AND JOINTING

Sand for bedding and jointing shall be free from substances that may be deleterious to blocks. In addition, the grading of the sand shall conform to that given in a) or b) below, as applicable, except that, where evidence satisfactory to the engineer has been provided to the successful previous use of sand having another grading, sand of such other grading may be used.

a) Bedding sand

Nominal Sieve size, (mm)	% passing
9,52	100
4,75	95-100
2,36	80-100
1,18	50-85
0,600	25-60
0,300	10-30
0,150	5-15
0,075	0-10

b) Jointing sand

Jointing sand shall pass a 1,18 mm sieve and shall contain 10- 50% of material that passes a 0,075 mm sieve.

COMMENTARY

In mining areas, the use of mine sand for bedding is generally acceptable. Similarly, experience has shown that certain relatively fine Cape Flats sands and sand from the Port Elizabeth area are acceptable. Such sands are the most economical as they are readily available.

Both the bedding and jointing sands should be free of deleterious soluble salts or other contaminants in order to avoid halo efflorescence which is unsightly and which may lead to a reduction in the skid resistance of the pavement.

Occasionally, the specifier may have the choice of several sands all of which meet the requirements set out above. Considerations should then be given to the particular shape and angle of shearing resistance, of the materials. Generally preference should be given to sands having sharp, angular particles and exhibiting high values of internal angle of friction because tests have shown that such materials yield better performance under traffic loads than sands yielding low values of internal angle of friction. If the angle of shearing resistance is not known, preference should normally be given to crusher sands or dune sands over river sand.

SIEVE GRADING

Sieve Size (by Log Scale)

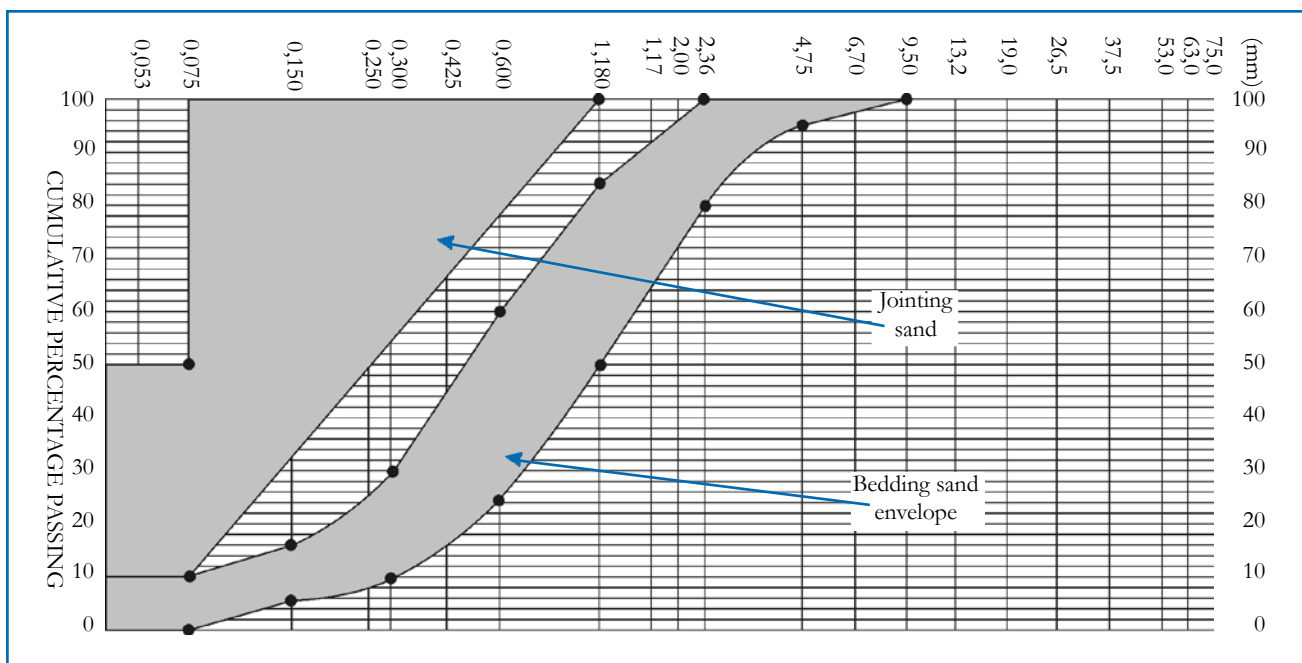



Besides satisfying the above requirements, bedding sand should be non-plastic. However, a slight percentage of clay in the jointing sand is ideal as it has sealing properties.

4 PLANT

4.1 GENERAL

Plant that is operated on or over units that have been laid shall be such that it does not cause damage to or disturbance of the units (see 5.6).

4.2 ROLLER

A roller shall be subject to approval and shall be a light (2-4 t) vibratory roller or, where so required (see 5.6.2), a heavy pneumatic-tyred roller.

COMMENTARY

A heavy-duty steel roller should not be used on paving as it will result in broken blocks.

4.3 MECHANICAL COMPACTOR

A mechanical compactor such as a flat-plate vibrator of high frequency and low amplitude, will be acceptable provided that it produces a) for units of thickness exceeding 80 mm, a centrifugal force of 16-20 kN at a frequency of 65 — 100 Hz on a plate area of 0,35-0,5m² (i.e. sufficient to cover at least 12 units); or b) for units of thickness not exceeding 80 mm, a centrifugal force of 7-16 kN at a frequency of 65 — 100 Hz on a plate area of 0,2 — 0,4 m² (i.e. sufficient to cover at least 10 units).

COMMENTARY

The vibration of the paving blocks into the bedding sand transforms the pavement from a series of unrelated independent blocks into a homogeneous whole. The purpose of vibration is to achieve the following objectives:

- a) to drive the paving unit into the bedding sand so that the bedding sand layer will not be compressed when the design load is applied.
- b) to force the bedding sand into the joints between units so as to achieve the wedging action of the sand.
- c) to level the surface of the pavers.

Under normal conditions the bedding sand will be forced into the joints to a height of approximately 20-30 mm.

5 CONSTRUCTION

5.1 PREPARATION

5.1.1 NEW WORK

5.1.1.1 GENERAL

Where the paving is to be laid on newly constructed earthworks or an existing subgrade that is too low, the subgrade and subbase shall be constructed in accordance with the requirements of SANS 1200 DM and SANS 1200 ME, respectively, and shall conform to the tolerance requirements of 6.2.

COMMENTARY

Where a paviour is responsible for the laying of the paving only, it is advisable that he checks that the levels of the earthworks conform to the specifications and drawings and where necessary gets the contractor to take remedial action. However, the main contractor is responsible for the strength and the line and level of the layerworks.

The standard tolerance on subgrade and subbase in both SANS 1200 and CASRA specification is not sufficient for good quality paving. The engineer must amend the specifications if concrete block paving is to be laid on the surface (see table 6.2 of SANS 1200 MJ)

5.1.1.2 DEPRESSIONS

Depressions shall be filled with material that has the physical properties specified for subbase material in SANS 1200 ME, and the material shall be compacted to 98% of modified AASHTO maximum density. Bedding sand shall not, under any circumstances, be used for this purpose.

COMMENTARY

Any shallow depression will require scabbling of the subbase to ensure a minimum 50mm filling.

5.1.1.3 FALL AND LEVEL

The top of the subbase shall be so constructed that surface water cannot pond and shall have a longitudinal fall of at least 1% and a transverse fall of at least 2%. The level after compaction shall be the designated level of the top of the subbase ± 10 mm [see 6.2. (b)].

COMMENTARY

The entire subgrade should be so prepared as to ensure adequate drainage and protection against rainfall and ground water by means of piped or channelled storm water and sub-soil drainage.

All piped and subsoil drainage construction located

beneath the pavement should be completed in conjunction with subgrade preparation before the commencement of subbase construction. All drainage and new service trenches within the pavement area should be backfilled to subgrade level with approved granular material.

The location of existing public utilities should be confirmed with the relevant authorities and adjustments arranged where there is insufficient cover. All utility trenches should be backfilled and compacted as required by the relevant authorities.

5.1.2 EXISTING SUBBASE SUBSTANDARD OR TOO HIGH

5.1.2.1 SUBSTANDARD LAYERS

Substandard layers and soft and unstable areas in the subbase (or subgrade or formation, as applicable) shall be replaced or strengthened as specified in 5.1.2.2 or 5.1.2.3, as applicable.

COMMENTARY

The subgrade shall be compacted to not less than the project specification requirements. Under no circumstances should further pavement construction proceed until the subgrade has been inspected and approved.

5.1.2.2 SUBBASE NOT STABILISED

Any portion of an existing subbase that has not been stabilised and is too high shall be lowered, harrowed and reconstructed to such depth that, after compaction, the subbase layer is of the same standard and thickness throughout or it shall comply with the requirements of the project specification and, in addition, the fall and level shall comply with 5.1.1.3.

5.1.2.3 STABILISED SUBBASE

Any portion of an existing stabilised subbase that is too high shall be lowered, harrowed and reconstructed to such depth that, after compaction, the subbase layer is of the same standard and thickness throughout or it shall comply with the requirements of the project specification and, in addition, the fall and level shall comply with 5.1.1.3. Depressions created in the course of lowering a stabilised subbase shall be filled with stabilised subbase material and compacted to form a subbase of at least the same standard as that of the existing stabilised subbase. Alternatively, in the case of depressions of depth greater than 50 mm, concrete having a 7 d cube strength of at least 5 MPa shall be used. The fall and level after compaction shall comply with 5.1.1.3.

COMMENTARY

The decision whether or not to use cement or lime treatment depends on the characteristics of the materials and whether it is required by the design.

The proportion of lime or cement needed depends on the characteristics of the soil and on specified requirements and is determined by laboratory tests.

Where cement treatment is required, the cement is usually CEM I 42,5, CEM II / A - S, V or W 32,5 or higher, CEM II / B - S, V or W 32,5, CEM III / A 32,5 or a 50/50 blend of CEM I 42,5 and milled granulated slag (SANS 1491 Part 1) or fly ash (SANS 1491 Part 2)

5.2 EDGE RESTRAINTS

Edge restraints consisting of kerbs or channels (see 3.2) or other approved edge strips, as scheduled or given on the drawings, shall be constructed on the subbase (or other formation) before any units are laid.

COMMENTARY

The function of the edge restraint is to retain the sand bedding and to ensure that units at the edge of the pavement do not creep outwards or rotate under load with consequent opening of joints and loss of interlock.

A separate edge restraint is unnecessary where an interlocking concrete block pavement joins an existing concrete pavement, or in the case of a flexible pavement having an asphaltic concrete surface not less than 100 mm thick.

Various designs of edge restraints are illustrated and the choice of which design to use is decided by factors for service loading, service life, aesthetic appeal and cost. Each type shown has been used successfully in particular applications. Various types of edge restraints are shown in the Appendix.

5.3 PLACING AND COMPACTING OF SAND BED

Bedding sand shall be spread over the subbase and evenly screeded in the loose condition so as to achieve a compacted thickness of 25 ± 10 mm. When the sand is spread, its moisture content shall be $6 \pm 2\%$. The sand bed shall be laid slightly in advance of the placement of the units but only to the extent that the particular area of pavement can be completed on the same day. Where the sand bed is accidentally compacted before the units are laid, it shall be raked and evenly rescreeded in a loose condition.

COMMENTARY

The depth of the sand bed must be adjusted according



to the amount of compaction, which will occur when the paving is vibrated. To determine this depth, a test area of paving should be laid on 30 mm of loose sand and compacted with three passes of the plate vibrator used to compact the finished pavement. The extent of settlement — the surcharge — should be noted and from this the precise depth of loose sand necessary to achieve a 25 mm thickness of compacted sand in the finished pavement can be determined.

Levels should be checked at regular intervals as laying proceeds. If levels change due to variation in the sand type or its moisture content, then the surcharge will change and blocks may have to be lifted and the sand raked and rescreeded to new levels before the blocks are relaid.

5.4 LAYING OF UNITS

The principal lines of the paving unit pattern as laid shall be as specified in the project specification or given on the drawings, and as agreed with the engineer before laying commences. If the said principal lines are not so specified, given or agreed upon, the units shall be laid in a herringbone pattern if the block shape permits and, where units cannot be so laid, they shall be laid with the long axis at right angles to the line of traffic. Except where curved patterns are required, the lines of the unit pattern shall be visually straight and parallel to major kerbs or buildings or other structures, as most appropriate and as approved.

Where appropriate, lines shall be set up at right angles to each other to control the alignment of the units. Joint widths shall be between 2 mm and 6 mm.

Whole units shall be laid first. Full depth closure units of special size or cut or part units split from whole units, shall be fitted into gaps around the perimeter and around service installations such as manholes.

Where plant has to be moved over an uncompacted newly laid pavement, boards shall be laid to prevent disturbance of the units.

COMMENTARY

It is essential that spaces between blocks be provided to avoid direct contact. Bonding is achieved by means of sand vibrated into the joints. A 3 mm space is considered to be the optimum but in practice is very difficult to achieve consistently. Blocks should be positioned without attempting to space them with absolute accuracy. With practice, blocks being laid can be bounced off those already laid to approximately the required distance. After vibration, settlement of the blocks into the bedding sand occurs. Joints should not be filled with sand until the initial vibration of the laid

blocks has been completed and the levels checked. Once joints have been filled, it is difficult to make adjustments to pavement profiles or to individual paving units. At the end of the day, the laid blocks should be vibrated and sanded to within one metre of the uncompleted face. When more than one operator is placing blocks especially on long laying faces, the operators should be rotated to avoid irregular spacing of blocks.

It is essential to ensure adequate joint widths in completed paving. Joints, which are too narrow, can result in edge and corner spalling under load while spaces, which are too great, prevent 'lockup' and load transfer between blocks. A good rule of thumb is that joint width should be as uniform as possible and should average 3 mm over 20 blocks.

Constant reference to string lines, and frequent adjustment to these lines will promote even joint width.

It should be recognised that progressive wear in the mould used for the production of the paving units will result in some increase in the plan area of units within nominated tolerances. Thus on major works where sections of pavement may require matching up during the construction programme, either matching deliveries should be stockpiled or sections of pavement separated by the provision of an edge restraint, or a contrasting section of paving units (e.g. a row of rectangular units).

5.5 FILLING GAPS IN UNIT PATTERN

Each gap where a closure unit cannot be used, shall be filled, after thorough pre-wetting of all units bounding the gap, with concrete that has a 24 hour cube strength of at least 15 MPa and contains aggregate of maximum nominal size 9,5 mm. Filling shall be kept to an absolute minimum and shall be to full unit depth in all cases. The concrete shall be cured for at least 24 hour by covering it with moist sand or approved plastic sheeting or hessian firmly held down at the edges. Where concrete is used for filling gaps, no compaction shall be carried out within 1m of such filling unit 24 hour after the filling has been completed or until the specified cube strength of 15 MPa has been attained, whichever occurs first.

COMMENTARY

Infill concrete should be avoided wherever possible. Refer to Detail P-PA-07

Where infill concrete is necessary, this process should only be undertaken once all compaction is completed.

Cutting paving units for infilling against edge restraints, etc., should be deferred until sufficient work has been completed to allow for a reasonably continuous operation. Hydraulic or mechanical guillotine block cutters or power saws are typically used for this purpose. The use of cut units smaller than about 25% of full unit size is not recommended, as these small units can be dislodged under traffic. Where herringbone pattern is used, it is recommended that the pattern be reorientated along the edge restraint. This will eliminate the need to cut blocks longitudinally. See detail P-PA-07 It is important to note that the gap between blocks and the edge restraint should comply with the joint width tolerances of 2-6 mm.

5.6 COMPACTION OF UNITS

5.6.1 GENERAL

The manner of compaction of units shall be such that damage to the units is prevented. At least two compaction passes shall be made over the paving as soon as practicable after laying, and before the introduction of any jointing sand. By the end of each day, compaction shall be completed to not closer than 1 m from any free edge. A uniform even surface shall be obtained over the paved area.

COMMENTARY

A temporary restraint should be installed against the free edge before compaction.

5.6.2 PAVING SUBJECT TO WHEEL LOADS EXCEEDING 30 kN

Paving that is likely, in terms of the project specification, to be subjected regularly to wheel loads exceeding 30kN shall, after joint filling (see 5.7) be finally locked up with at least five passes of a heavy pneumatic-tired roller over the entire area of paving. The manner of compaction shall be as specified in 5.6.1.

COMMENTARY

Compaction with heavy-duty plate compactors (weight 300-600kg, plate area 0,5 — 0,6 m² and centrifugal force 30-65 kN) ensures that the pavement is in a 'locked up' condition; where very high loads are expected in the early life of the pavement, proof rolling should be carried out.

5.6.3 DAMAGED UNITS

Damaged units shall be replaced and compacted before joint filling is carried out.

5.6.4 NO TRAFFIC UNTIL JOINTS FILLED

No vehicular traffic shall be allowed over the paving until all joints have been filled with sand (see 5.7).

COMMENTARY

This includes construction traffic

5.7 JOINT FILLING

The joints shall not be filled until all closure units have been inserted, all the necessary adjustments to line and level have been made and the pavement has been subjected to at least two passes of the compactor.

Sand that complies with 3.3 (b) shall be broomed into the joints until they are full, and sufficient passes of a plate compactor shall be made to settle the joint filling. The procedure shall be repeated until the joints remain full after compaction.

On completion of compaction, all excess sand shall be broomed off and disposed of. Damage caused during compaction shall be made good by the contractor at his own expense.

COMMENTARY

Both the sand and the paving units should be as dry as possible when sand is spread. Due to the narrowness of the joints, damp sand may bridge across them and resist compaction without this being obvious at the surface. Fully filled joints are essential for the achievement of the full structural performance of the pavement throughout the service life of the pavement.

If construction work is still in progress, excess jointing sand can be left in place after completion and swept off at a later stage.

The sand should be brushed and not washed into the joints.

6 TOLERANCES

6.1 GENERAL

6.1.1 PAVING AS LAID

In addition to compliance with 6.2 (c), the finished surface of the paving shall, in the opinion of the Engineer, present a regular and smooth appearance to the eye.

6.1.2 METHOD OF MEASUREMENT OF DEVIATIONS

Any deviation from flatness of a plan surface will be measured as the maximum deviation of the surface from any straight line of length 3 m joining two points on the surface, determined by means of a straight-edge the ends of which are supported on identical blocks of suitable thickness placed over each of the points.



6.1.3 FREQUENCY OF CHECKS ON SMOOTHNESS

The frequency of checks on smoothness carried out by the Contractor shall, in the case of roads, conform to the relevant requirements of Subclause 6.3 of SANS 1200 M and, where an area other than a road is being paved, a check shall be carried out on every 300m² (max.) of area paved.

6.2 PERMISSIBLE DEVIATIONS

The permissible deviations shall be as given in the table below:

COMMENTARY

Tolerance in c) 2) (i) is very difficult to achieve and is not critical provided that adequate falls are met.

Where economy is desired and the tolerances easily attainable by the average earthworks contractor in respect of the subbase (and hence the segmented paving), are deemed to be acceptable even though they do not conform to Degree of Accuracy I, the criteria for permissible tolerances may be relaxed. The tolerances on the paving units, i.e. a 1) to 4) of the table, and other requirements of SANS 1058 should not be relaxed under any circumstances.

It should be noted that the permissible deviations of top of subbase layer and finished paving are the same. The bedding sand layer should not be used to make up for inaccuracies of level of the top of the subbase layer or top of the compacted subgrade if a subbase is not constructed.

7 TESTING

7.1 GENERAL

7.1.1 CHECKING

The Contractor shall carry out sufficient checks to satisfy himself that the materials used and the workmanship (construction, tolerance and strength) attained comply consistently with the specified requirements. Checks will be carried out by the Engineer and the results made available to the Contractor.

7.1.2 STANDARD OF FINISHED WORK NOT TO SPECIFICATION

The Engineer may carry out such checks, as he

ITEM	PERMISSIBLE DEVIATION, (mm) DEGREE OF ACCURACY		
	III	II	I
a) Units as Manufactured			
1) Deviation of length from nominal length	*	*	± 2
2) Deviation of width from nominal width	*	*	± 2
3) Deviation of depth (or thickness) from nominal depth (or thickness)	*	*	± 3
4) Deviation of squariness (measured as specified in SANS 1058)	*	*	± 2
b) Foundation layers			
1) Deviation of top subbase layer from designated level	*	*	± 10
2) Smoothness of top subbase layer measured on a 3m straight line in any direction	*	*	± 10
3) Thickness of 25 mm compacted sand bedding layer	*	*	± 10
c) Finished paving. The finished surface of the paving shall, 3 months after opening to traffic, be accurate to within the following limits:			
1) Line of pattern			
i) Deviation from any 3 m straight line maximum	*	*	10
ii) Deviation from any 20 m straight line maximum	*	*	20
2) Vertical deviation from 3 m straight line			
i) at kerbs, channels, gullies, manholes and other edge restraints	*	*	+ 3, —0
ii) elsewhere (subject to adjustment as necessary for vertical curve)	*	*	+10, —15
3) Surface levels of adjacent units, difference not to exceed	*	*	3
4) Deviation of finished surface level from designated level, subject to compliance with 6.1.1 and 7.6	*	*	+10, —15

* As stated in the project specification, if required.

deems necessary at any point or at any depth or on any layer. Where the Engineer's checks reveal that the material used or that the construction to tolerance standard achieved does not comply with the applicable requirements of the specification, or that the compaction specified has not been attained, the Contractor shall so rectify the work that the materials, construction and tolerance comply with the said requirements and the compaction specified is attained.

7.2 TRIAL SECTION

Commencing from at least one permanent edge restraint the first section of paving of length at least 20 m and of width approximately 6 m laid as part of the permanent paving will be regarded as a trial section for the purpose of assessing the Contractor's ability to produce a paving that complies with the applicable requirements of the specification.

Full scale paving unit laying shall not commence until the trial section has been laid by the Contractor and approved by the Engineer. Subsequent laying operations shall be carried out using materials of at least the same quality and with the same standard of workmanship as in the approved trial section. The Contractor shall remove at his own expense, any trial section that is not approved.

COMMENTARY

The requirement for the construction of a trial section should not be mandatory for experienced contractors or where the size and importance of the contract does not warrant such preliminary work.

For labour-based projects, where skills training is an integral part of the training, it is recommended that construction begins on a minor or subsidiary road. This will ensure that all the teething problems are resolved before work starts on the major road.

This area must be demarcated and no traffic allowed onto it at all.

7.3 SUBBASE, FORMATION AND OTHER FOUNDATION LAYERS

The subbase, formation and other foundation layers shall be subjected to testing in terms of SANS 1200 DM and SANS 1200 ME, as applicable.

7.4 BLOCKS

7.4.1 WET STRENGTH TEST

The relevant test given in SANS 1058 shall be used to determine whether blocks comply with the requirements for wet strength given in 3.1

COMMENTARY

The compressive strength is stated in SANS 1058 clause 6.4.

7.4.2 OTHER TESTS

Blocks shall be subjected to such other tests as are given in SANS 1058 and in The Concrete Manufacturers Association Paving Manual Book 2.

7.5 CONCRETE FOR GAP FILLING

The concrete used for gap filling shall be subjected to testing in accordance with SANS 1200 G or SANS 1200 GA, as applicable.

COMMENTARY

This practice is generally not recommended. It is preferable that the blocks are cut to fill gaps. Generally pavers alongside the edge restraint can be realigned so that small pieces are eliminated.

7.6 KERBS, CHANNELS AND OTHER DEVICES

Kerbs, channels and other devices used for edge restraints shall be subjected to testing in accordance with SANS 1200 MK.

7.7 PONDING

Where the Engineer is of the opinion that, notwithstanding compliance by the Contractor with the requirements of 5.1.1.3, ponding may occur on the finished surface, the engineer may order the whole or any part(s) of the surface to be flooded with water to determine whether ponding will occur. Rectification of areas where ponding is found to occur shall be carried out by the Contractor at his own expense. If ponding does not occur, the Employer shall bear the cost of the test.

COMMENTARY

If permissible deviations relating to the finished surface of the paving are to be allowed, then the fall of the surface for drainage should be steeper than 1 in 50.

Ponding is generally as a result of incorrect earthworks.



PATTERNS – GENERAL

NOTE: Use of Computer Aided Design (CAD). The following details in this manual are available on CD Rom in Caddie. Auto CAD and DXF format. Please contact the Concrete Manufacturers Association if you require these formats.

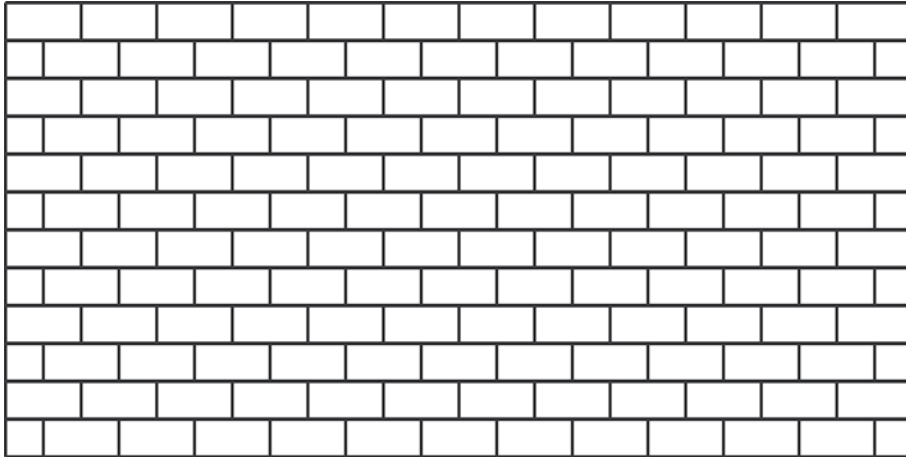

STRETCHER BOND

P-PA-01

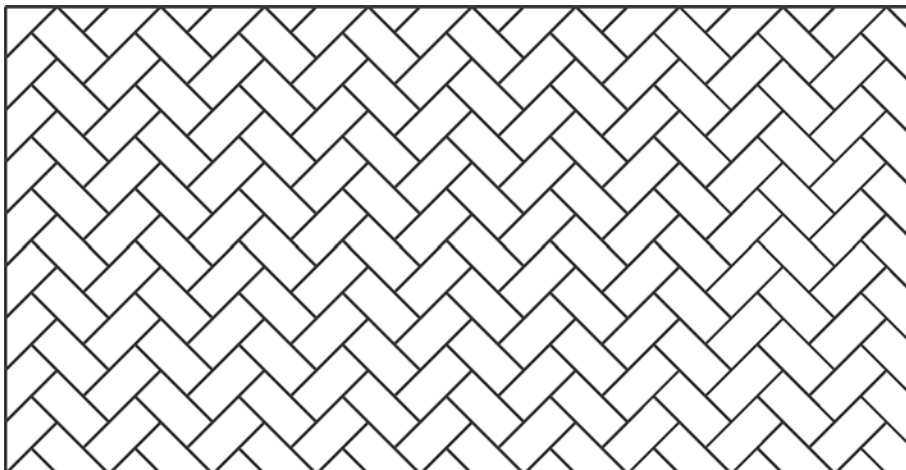

HERRINGBONE

P-PA-02

Recommended for
roadways and
industrial applications

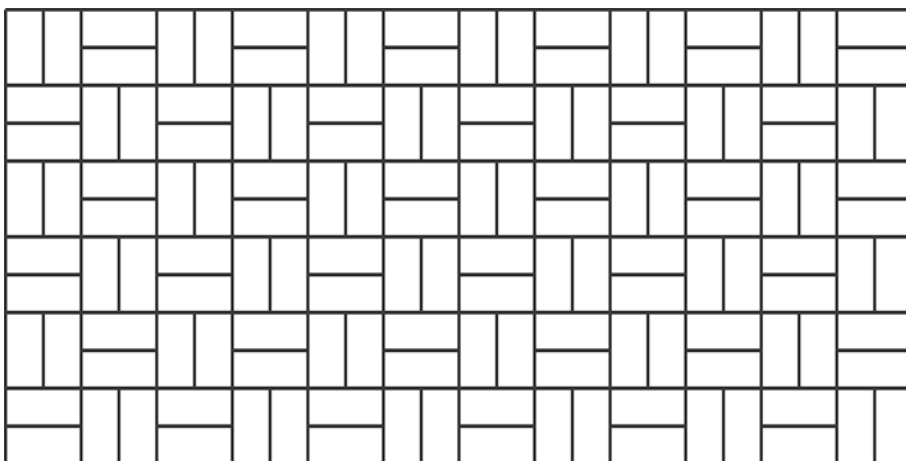

PARQUET OR BASKETWEAVE

P-PA-03

PATTERNS – ADAPTATION OF PATTERNS TO CHANGES IN ALIGNMENT

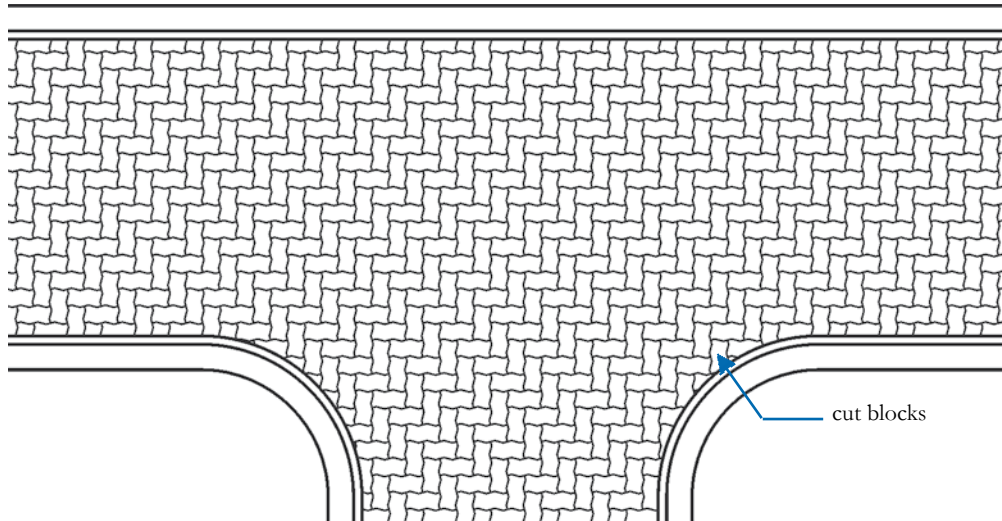

P-PA-04

(A) INTERSECTION LAID IN HERRINGBONE PATTERN

P-PA-05

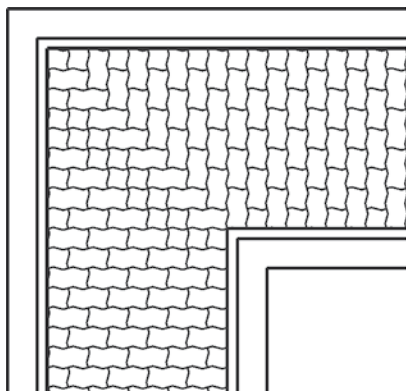

(B) 90° CHANGE IN ALIGNMENT USING STRETCHER BOND

P-PA-06

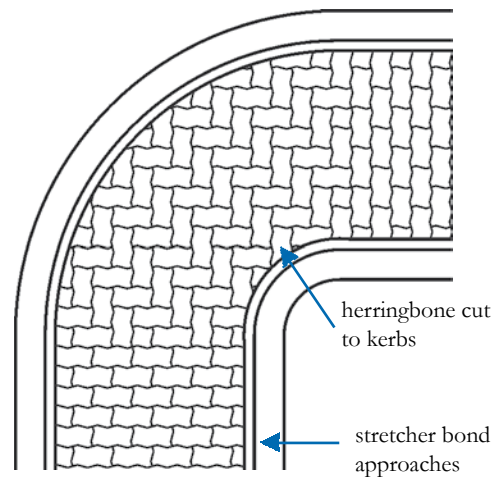

(C) USE OF HERRINGBONE PATTERN BETWEEN STRETCHER BOND PAVEMENTS

NOTE: There will be occasions when paving around a large area or building will not tie-in and a straight cut joint will be necessary. (See Detail P-PA-09)



PATTERNS – DETAILS AT EDGE RESTRAINTS

P-PA-07

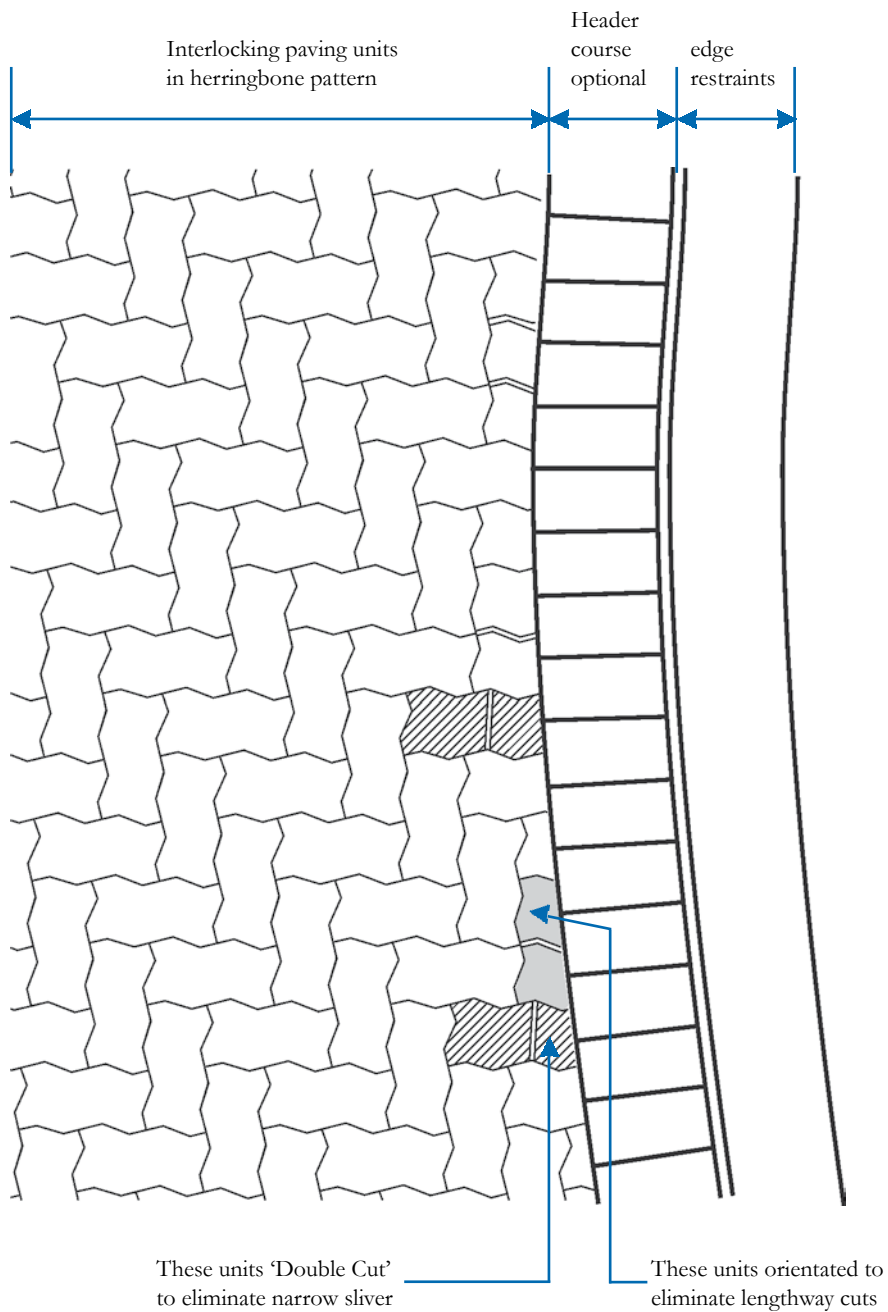

DETAIL SHOWING USE OF EDGE BLOCKS

NOTE: By making localised adjustments to the main laying pattern blocks can be re-positioned to eliminate the likelihood of having to cut slender pieces

PATTERNS – BLOCK TIE-IN TO BITUMEN SURFACES

P-PA-08

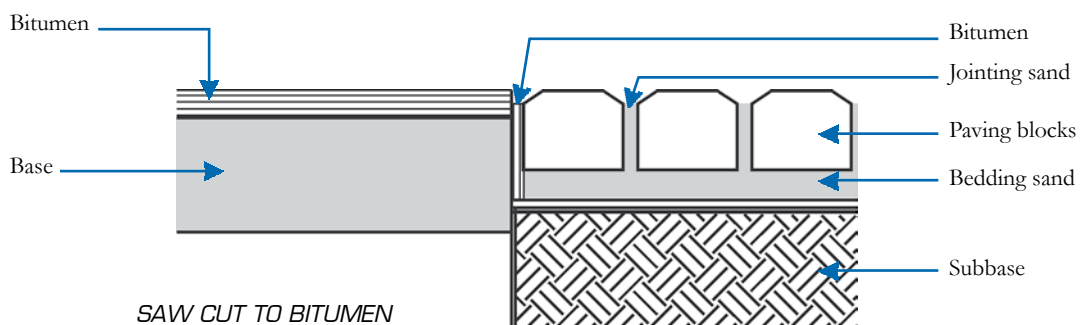
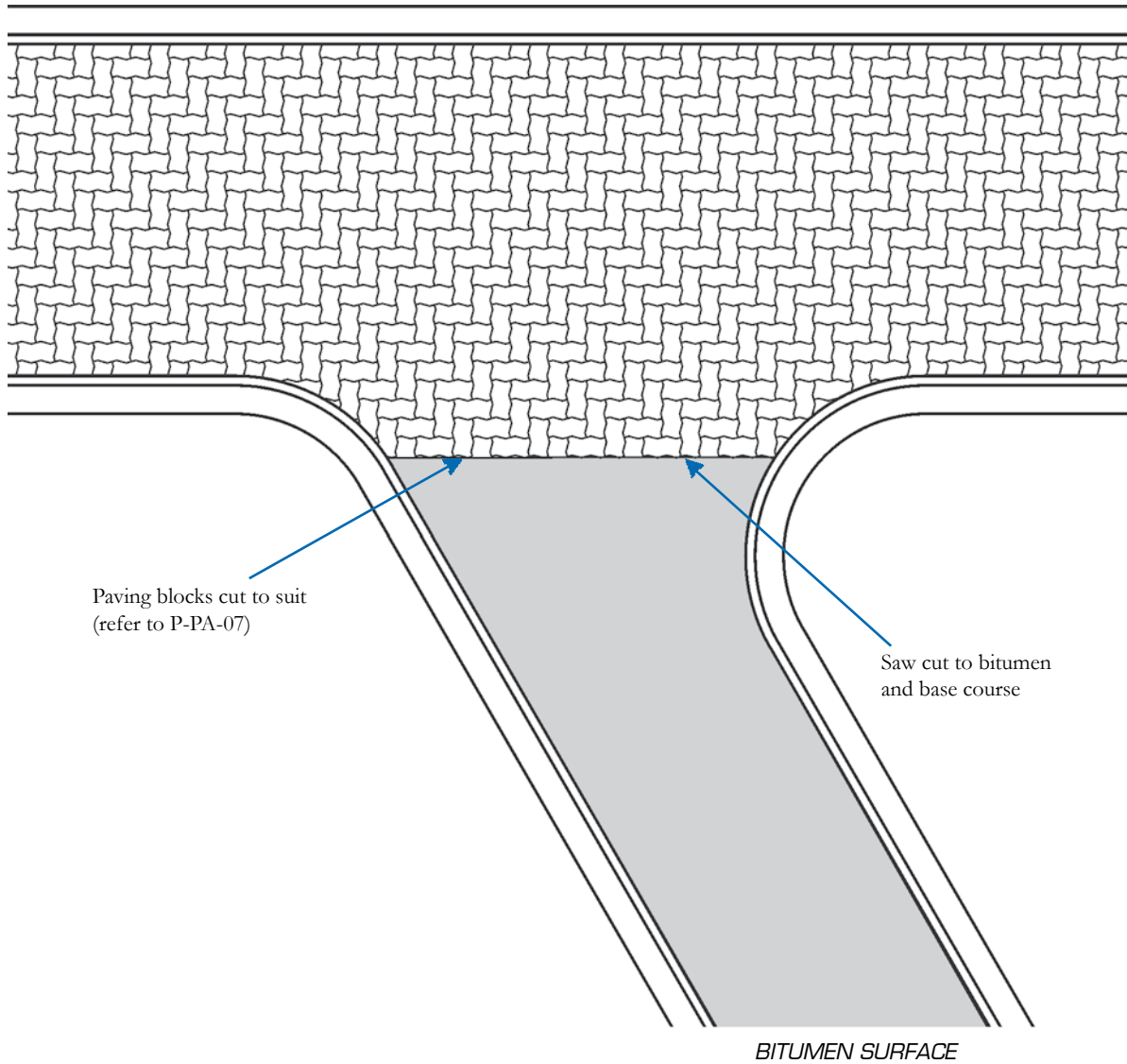



PATTERNS – CUT JOINT AT CHANGE IN PATTERN ORIENTATION

P-PA-09

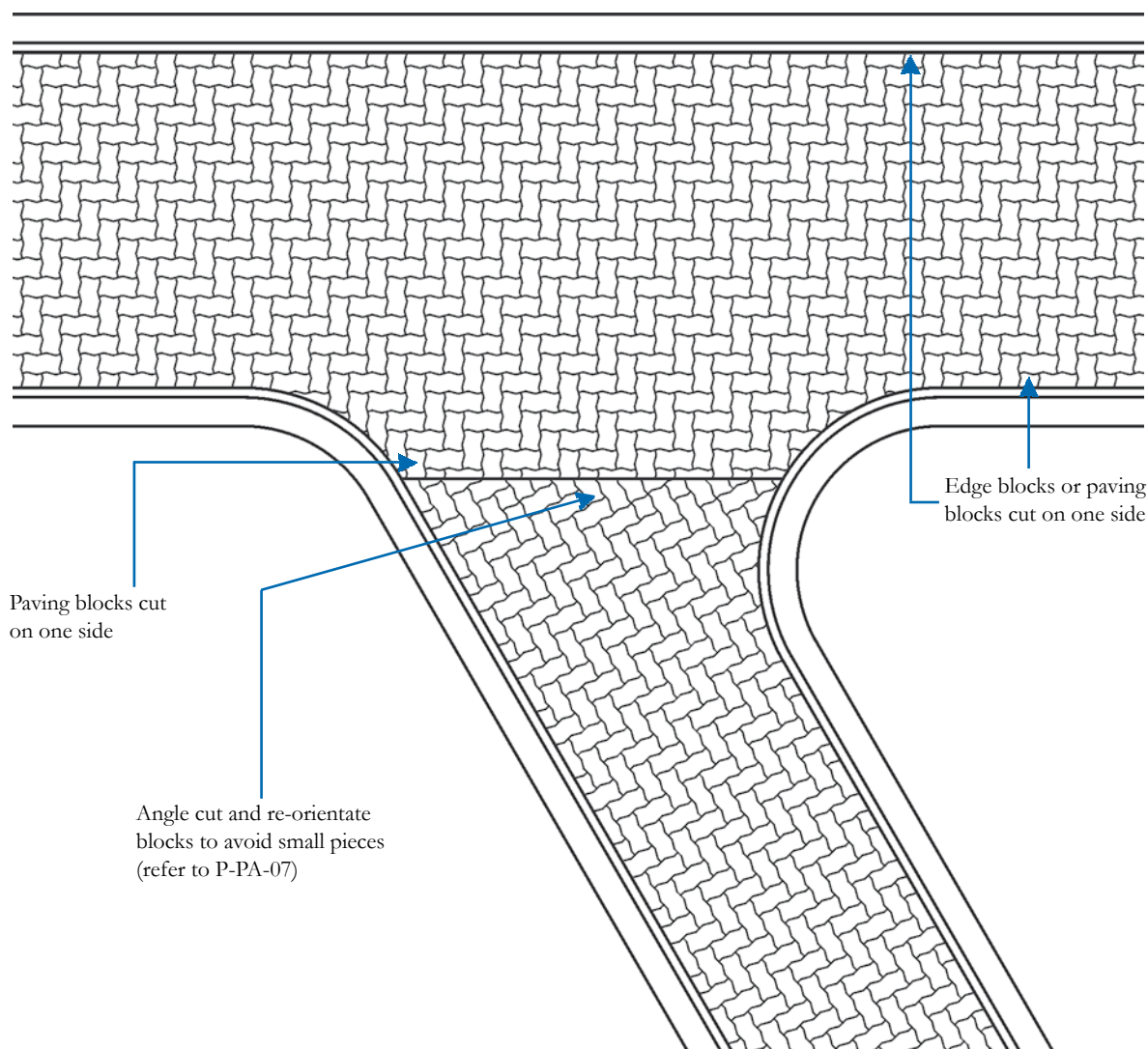

PATTERNS – BLOCK ORIENTATION THROUGH CURVES

P-PA-10

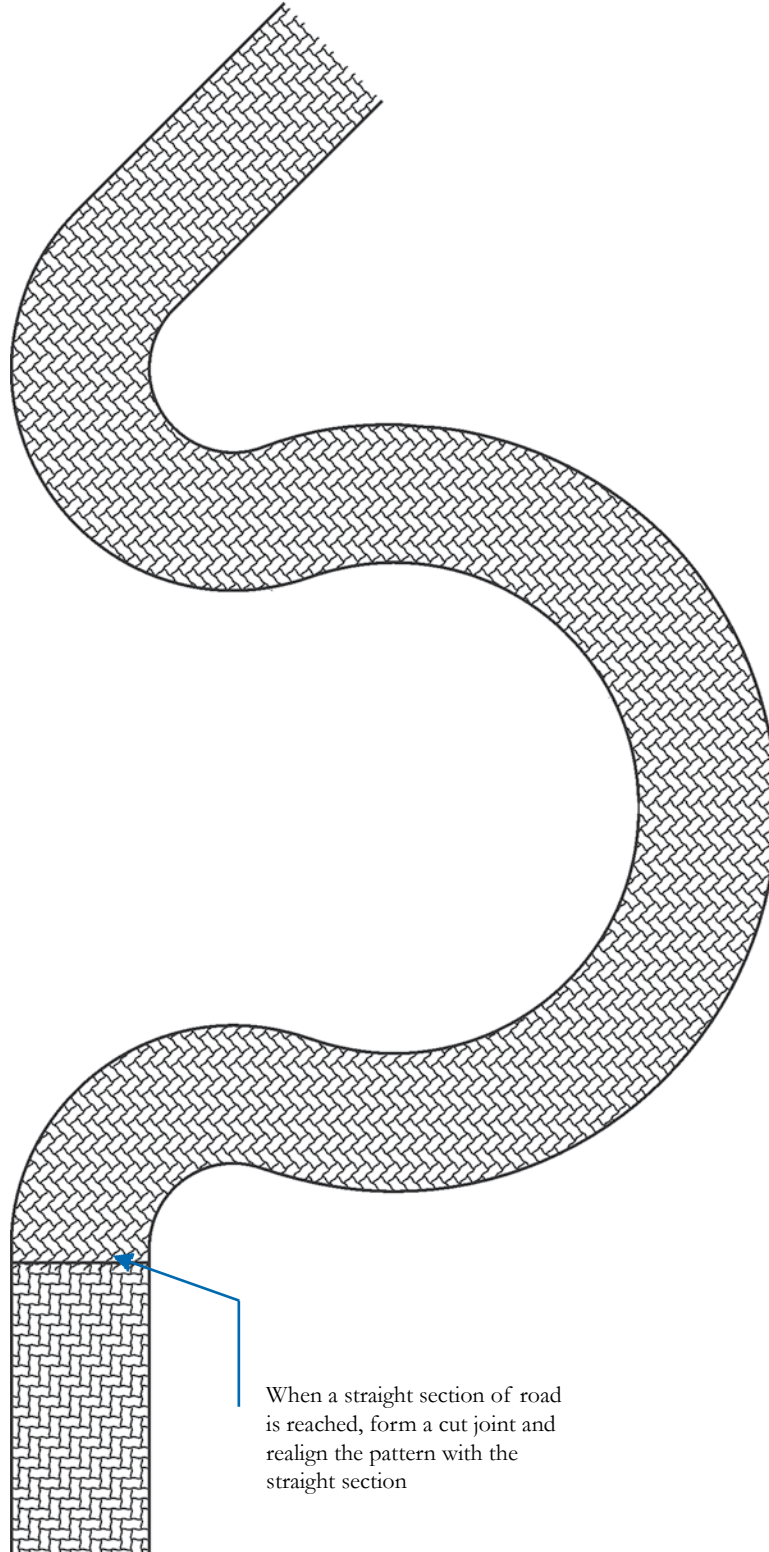

When a straight section of road is reached, form a cut joint and realign the pattern with the straight section



CONCRETE SLAB DETAILS DRAINAGE OF BEDDING SAND LAYER

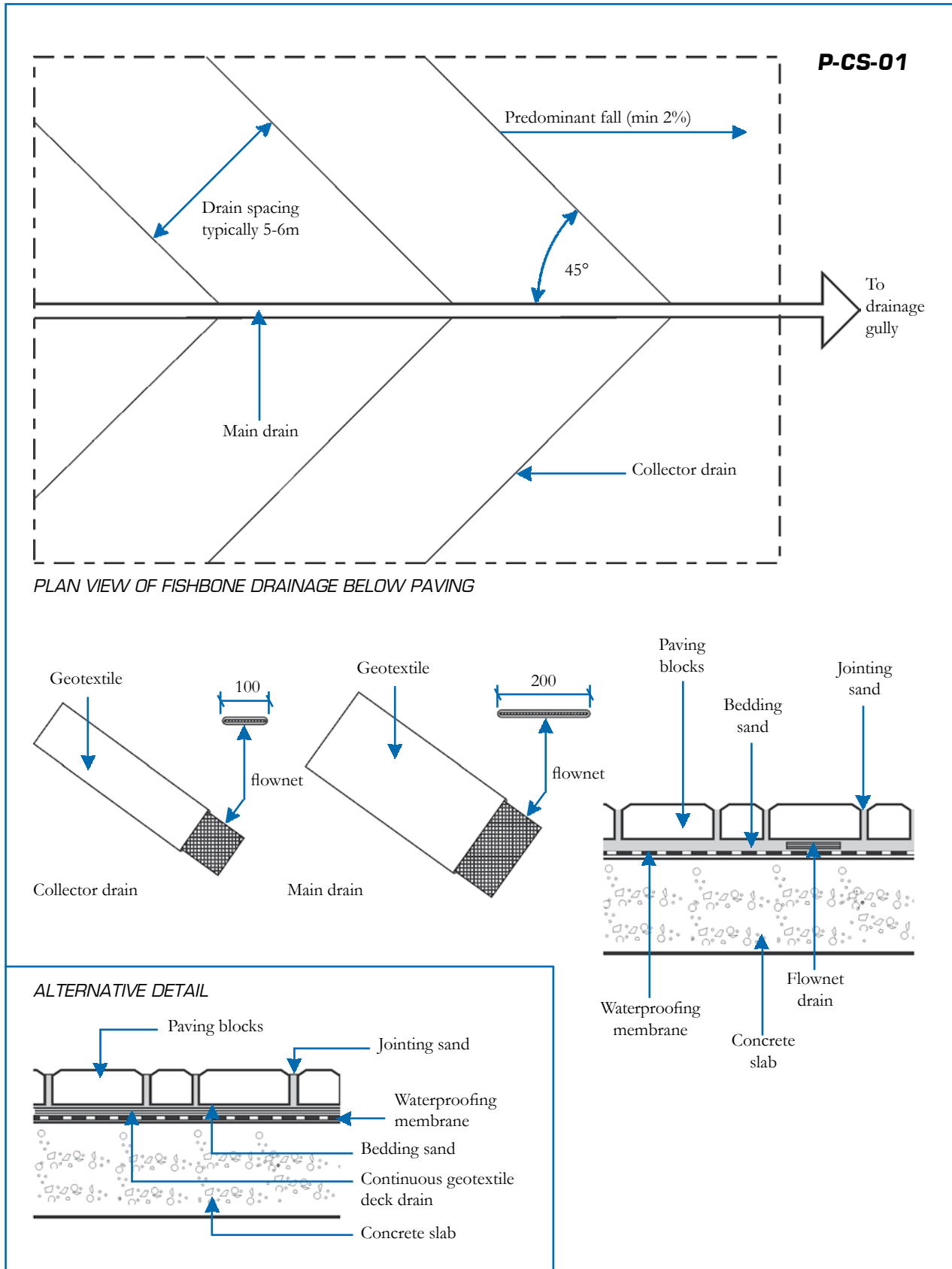

CONCRETE SLAB DETAILS

P-CS-02

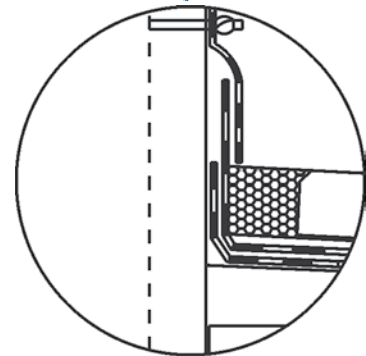
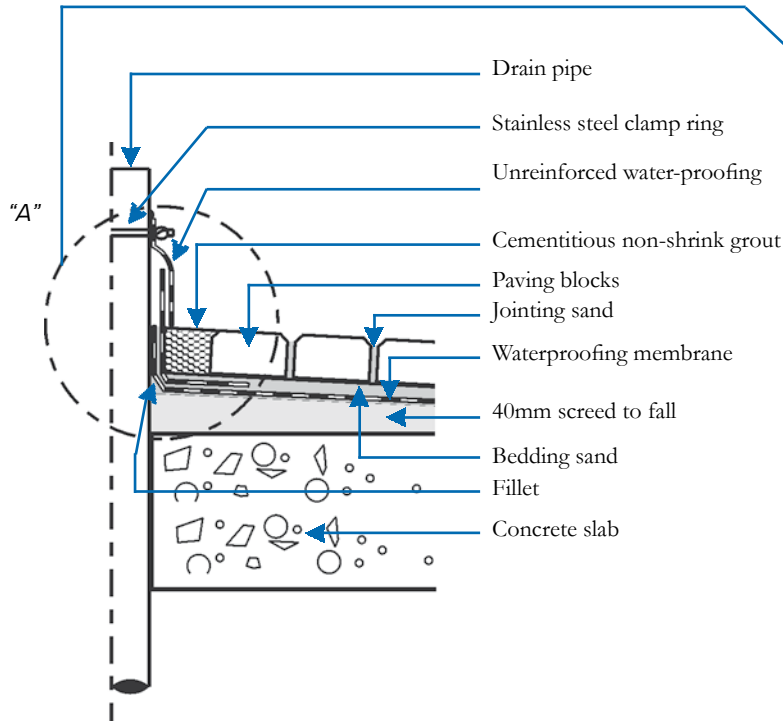

DETAIL "A"

DRAIN PIPE THROUGH SLAB

P-CS-03

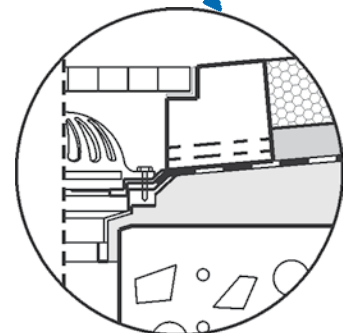
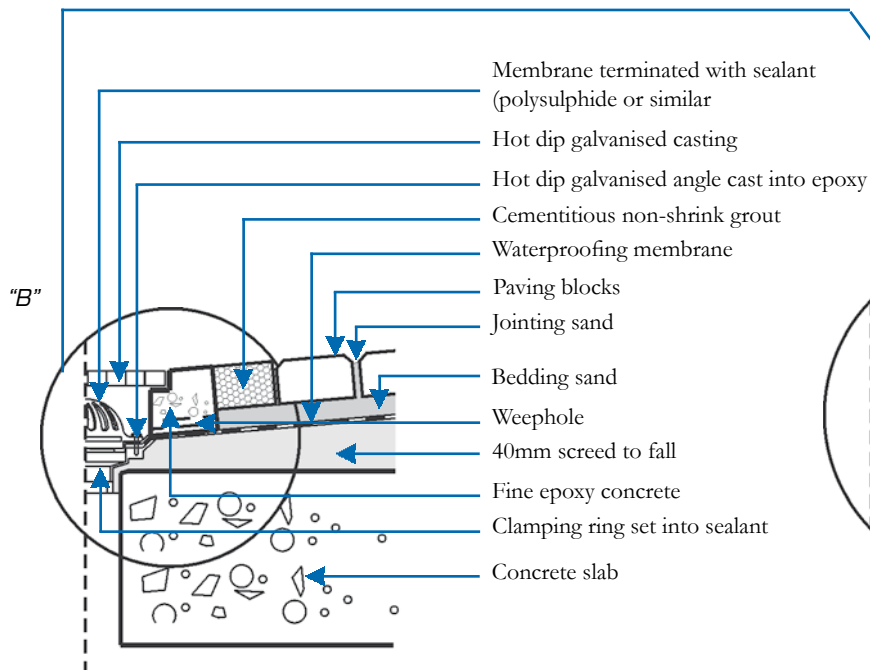

DETAIL "B"

FULLBORE OUTLET



CONCRETE SLAB DETAILS

P-CS-04

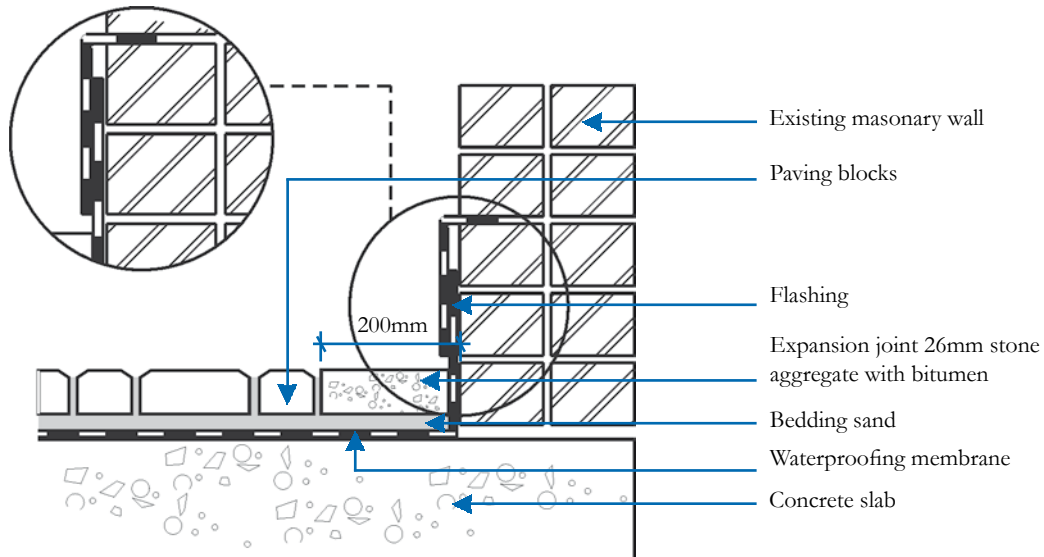

SLAB/WALL JUNCTION SHOWING EXPANSION DETAIL

P-CS-05

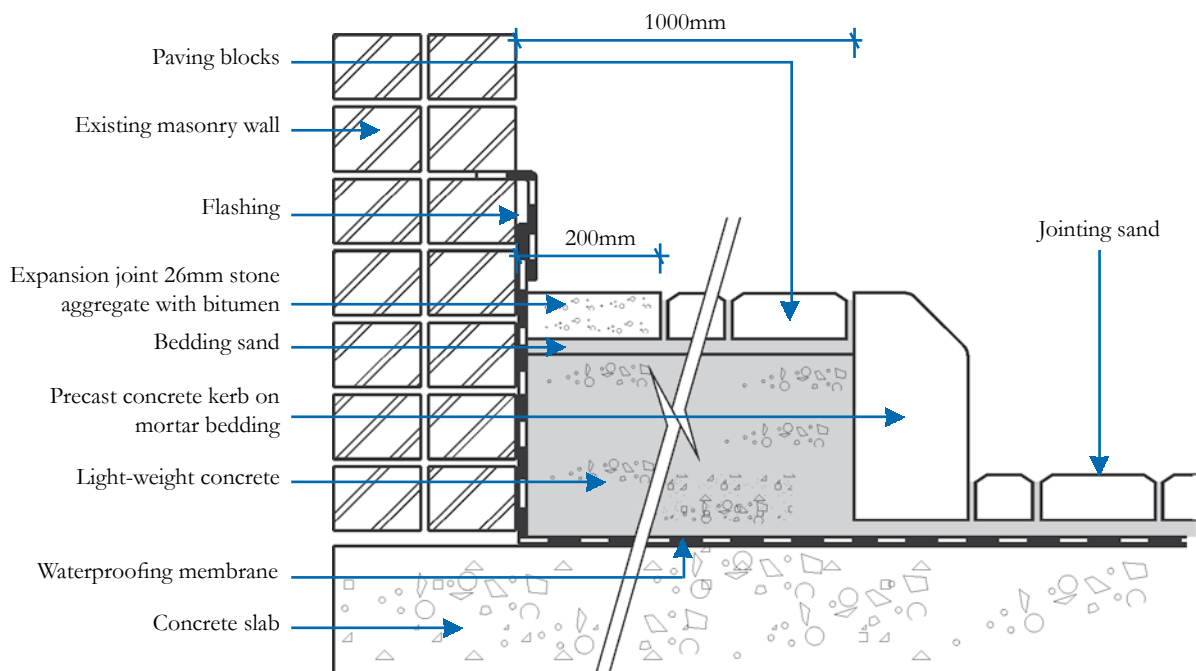

SLAB/WALL JUNCTION WITH EDGE RESTRAINT

CONCRETE SLAB DETAILS

P-CS-06

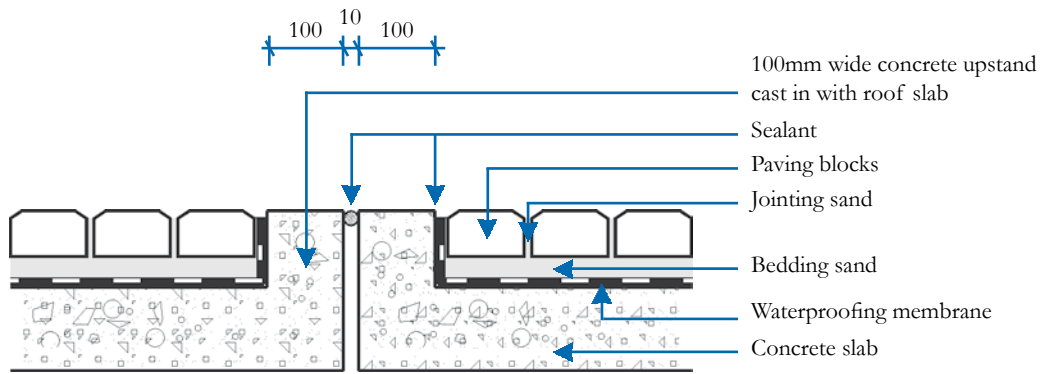

PAVING OVER EXPANSION JOINTS IN CONCRETE SLAB-DETAIL A

P-CS-07

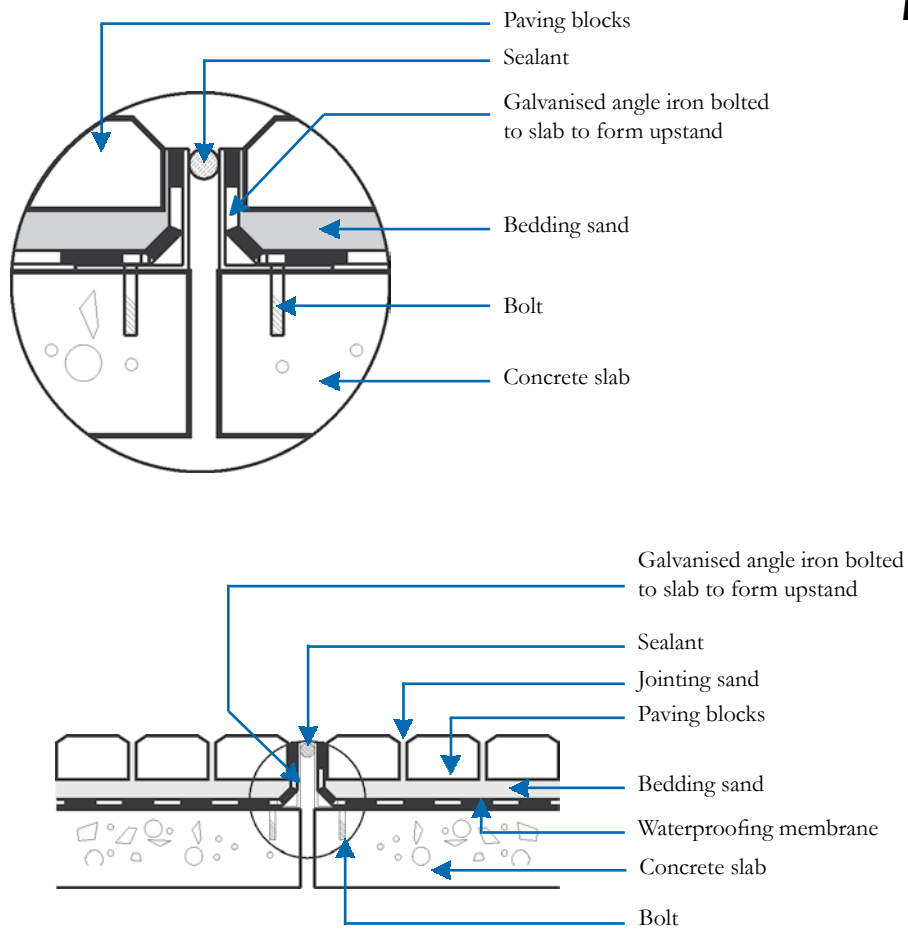

PAVING OVER EXPANSION JOINTS IN CONCRETE SLAB-DETAIL B



PENETRATIONS

P-MH-01

Concrete infill min. 100mm thick

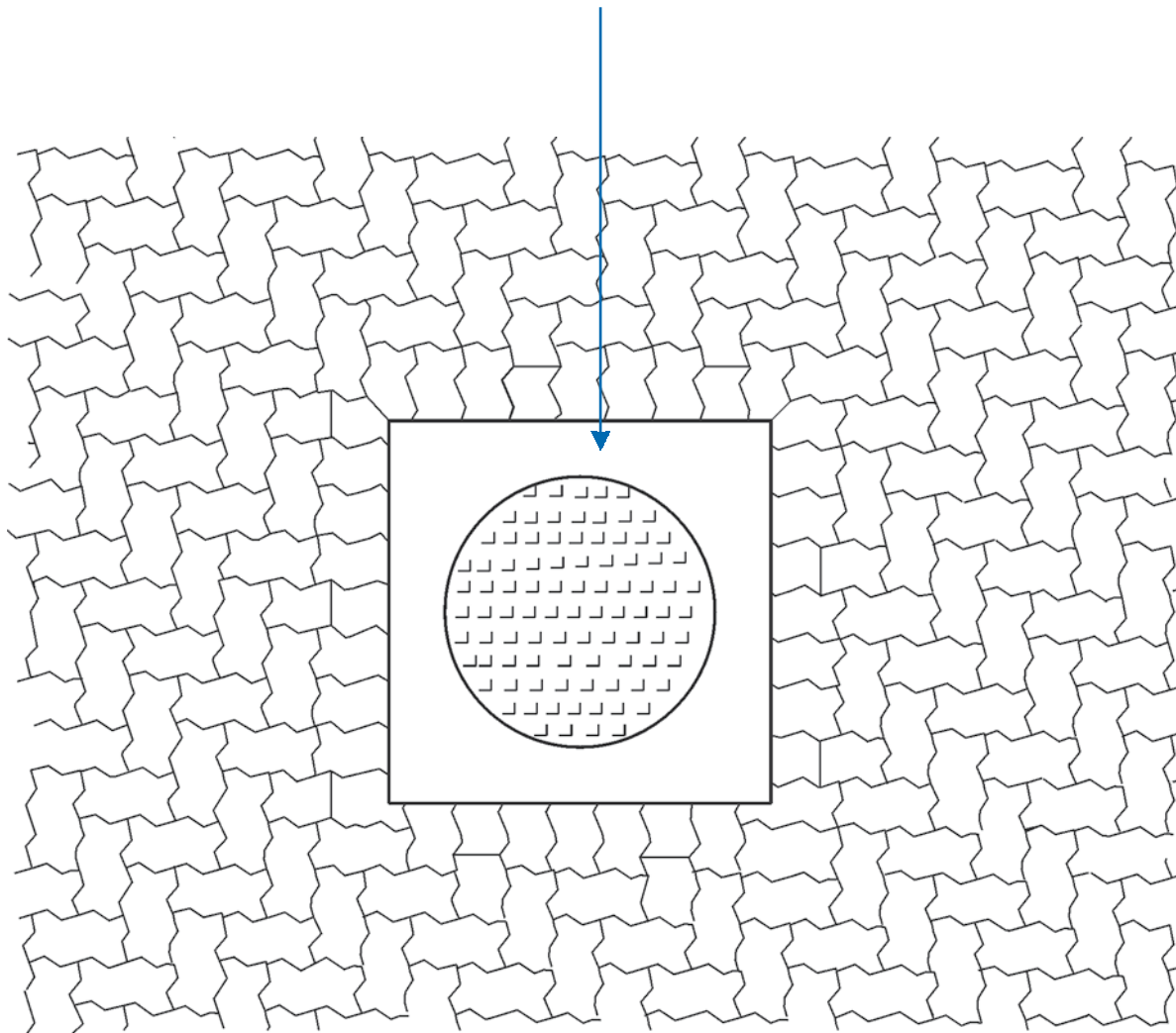

NOTE: Special attention to the compaction and possible stabilisation is required for the backfill near manholes to prevent subsidence

STEEP SLOPES

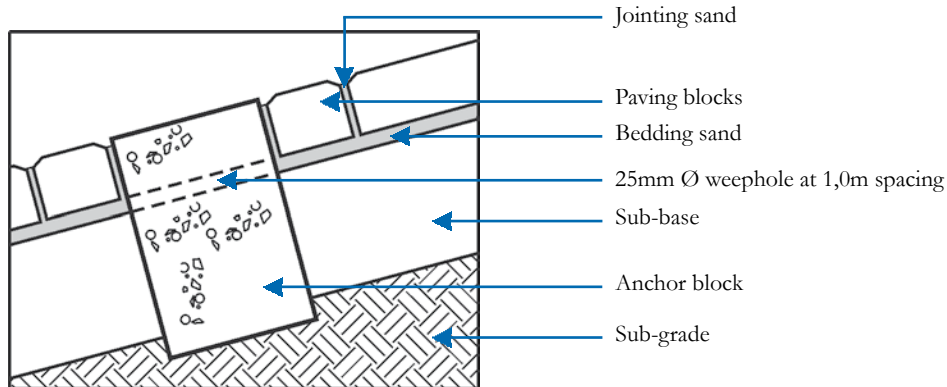

P-SL-01

DETAIL OF ANCHOR BLOCK ON STEEP SLOPES

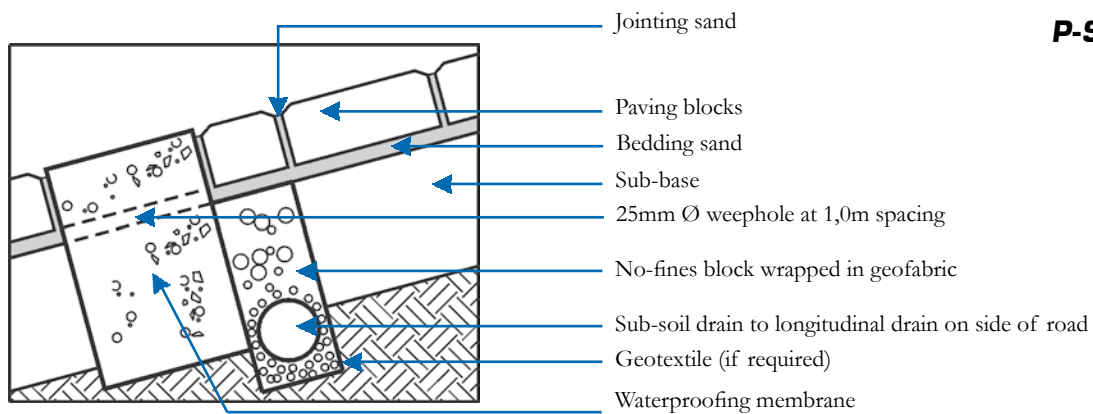

P-SL-02

DETAIL OF DRAINAGE TO BEDDING SAND LAYER — DETAIL A

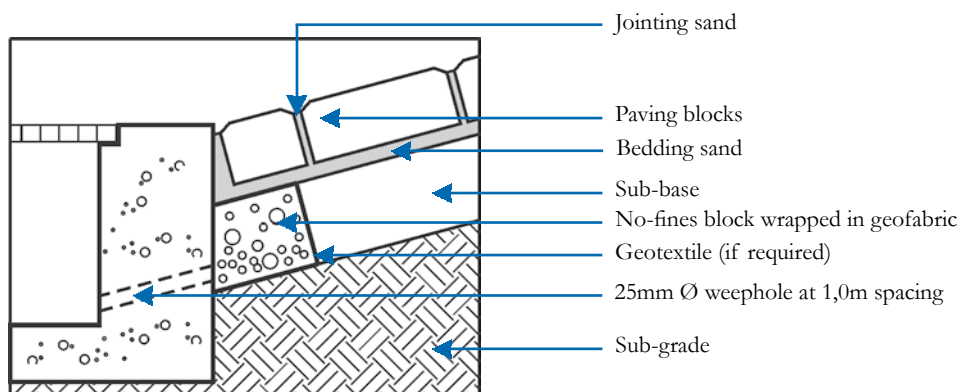

P-SL-03

DETAIL OF DRAINAGE TO BEDDING SAND LAYER — DETAIL B

NOTE: For ease of construction, it is recommended that the blocks are laid continuously up the gradient. There after sufficient rows of blocks are uplifted at the position of the beam, the sub-base excavated to the required depth and width and the beam cast



SURFACE DRAINAGE DETAILS

P-DD-01

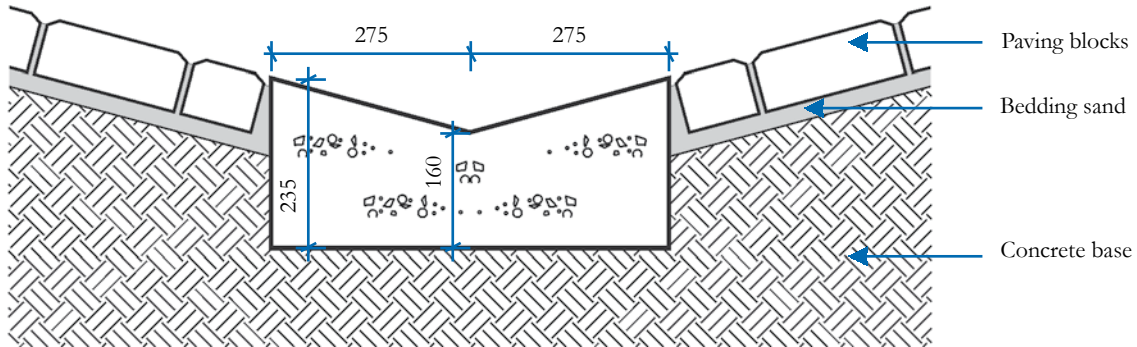

DRAINAGE DETAIL A (USING INSITU CONCRETE)

P-DD-02

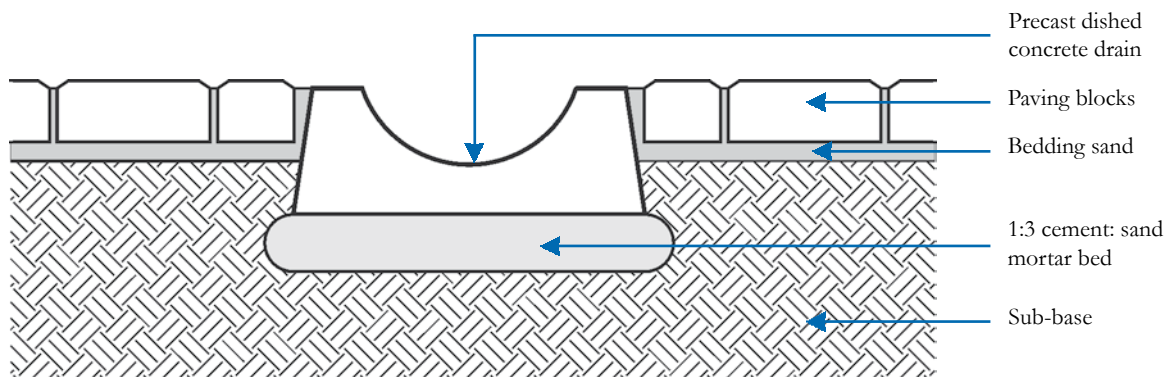

DRAINAGE DETAIL B (USING PRECAST DRAIN)

P-DD-03

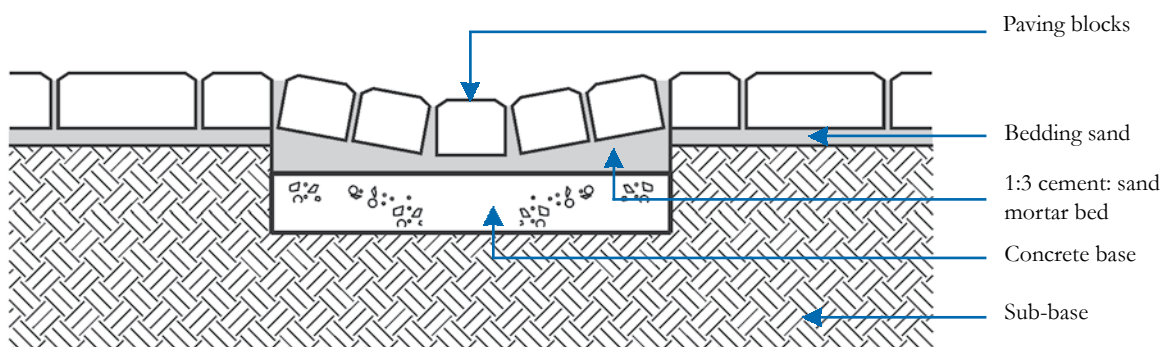

DRAINAGE DETAIL C (USING BLOCK PAVING)

EDGE RESTRAINTS FOOTPATHS

P-ER-01

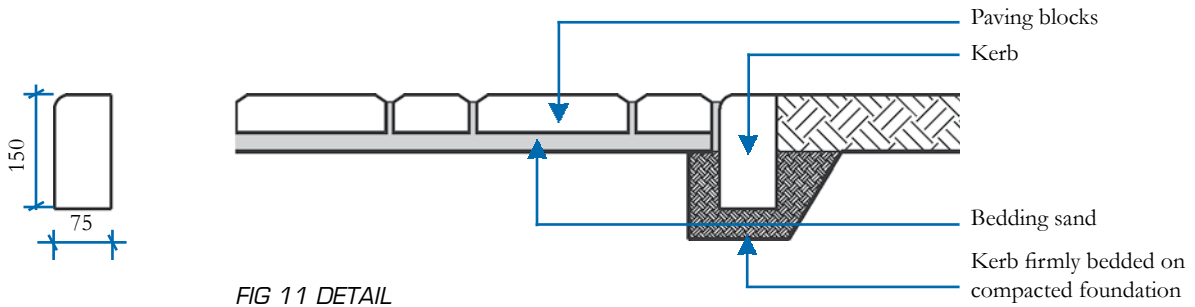

P-ER-02

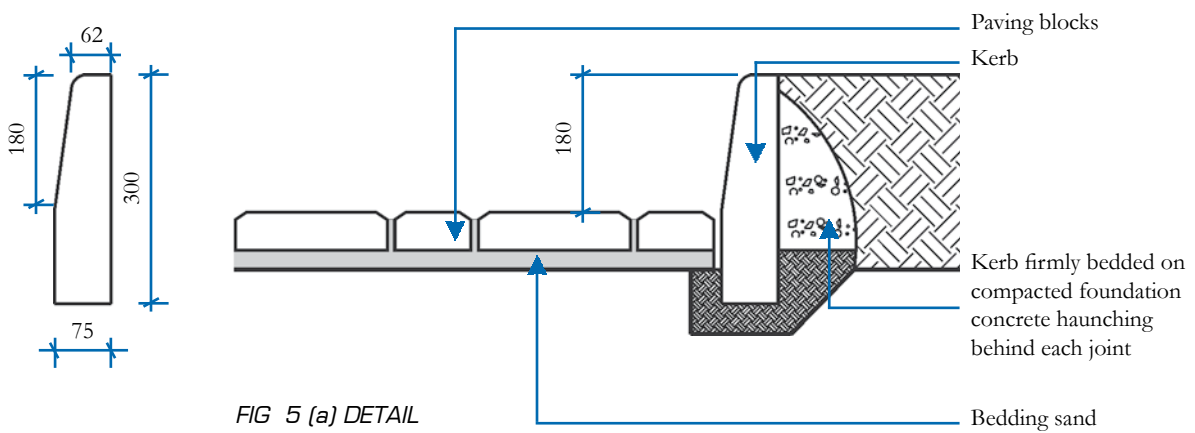

P-ER-03

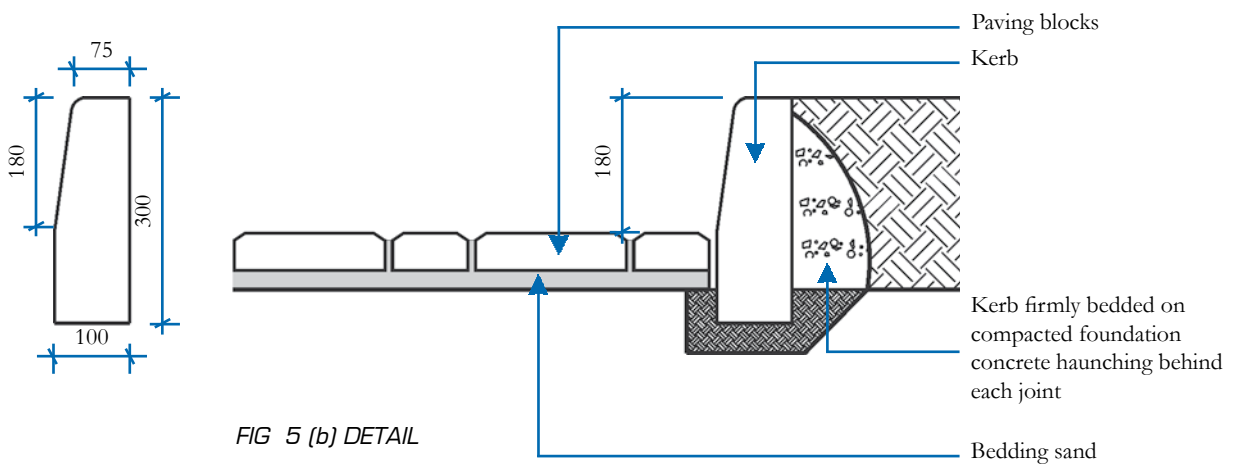

NOTE: Paver thickness 50mm

Precast concrete kerbs should comply with SANS 927-2003

Kerbs are generally supplied in lengths of 0,33m or 1,0m



EDGE RESTRAINTS LIGHT TRAFFIC

P-ER-04

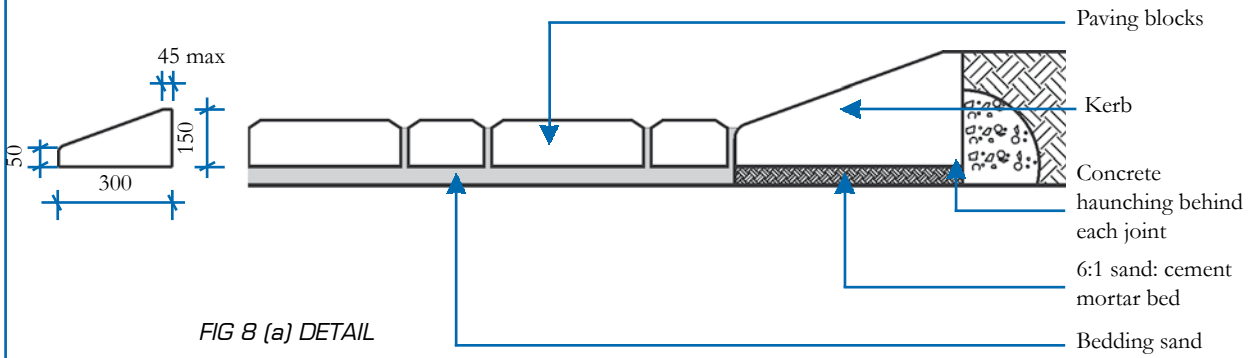

P-ER-05

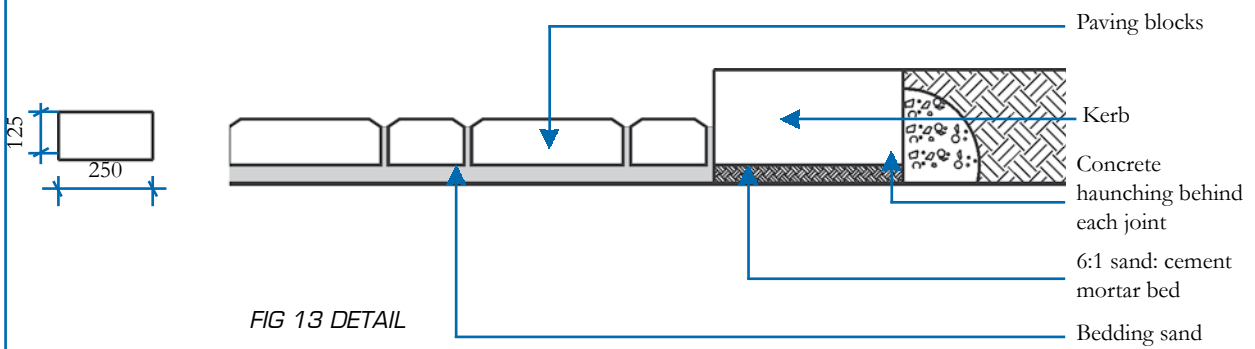

P-ER-06

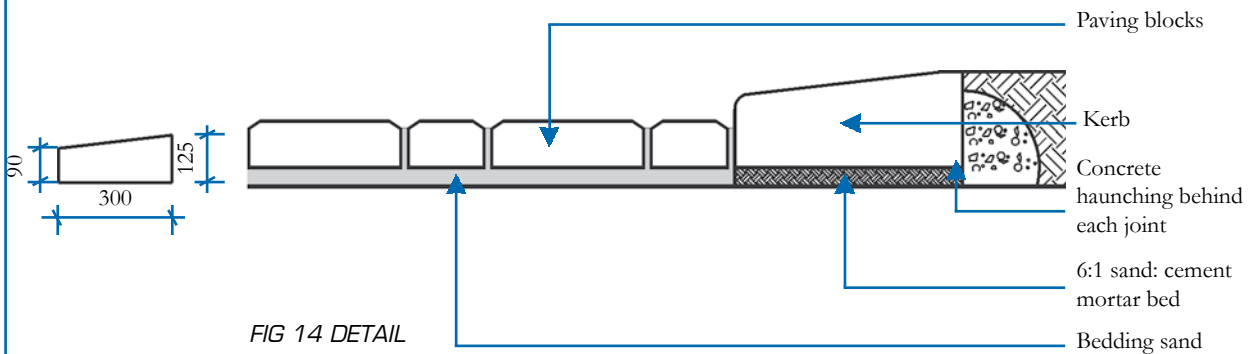

NOTE: Paver thickness 60mm

Precast concrete kerbs should comply with SANS 927-2003

Kerbs are generally supplied in lengths of 0,33m or 1,0m

EDGE RESTRAINTS HEAVY TRAFFIC

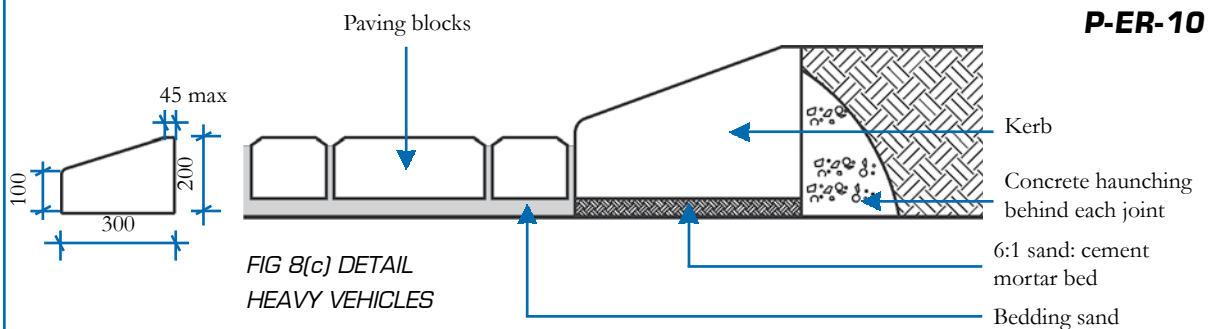
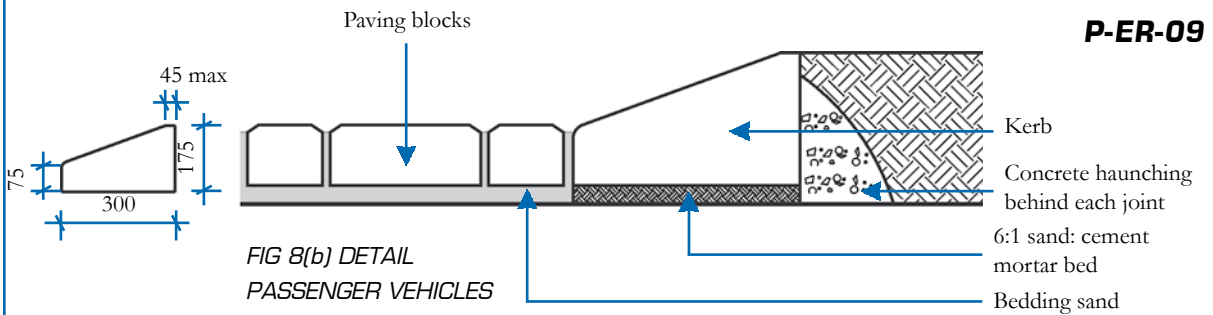
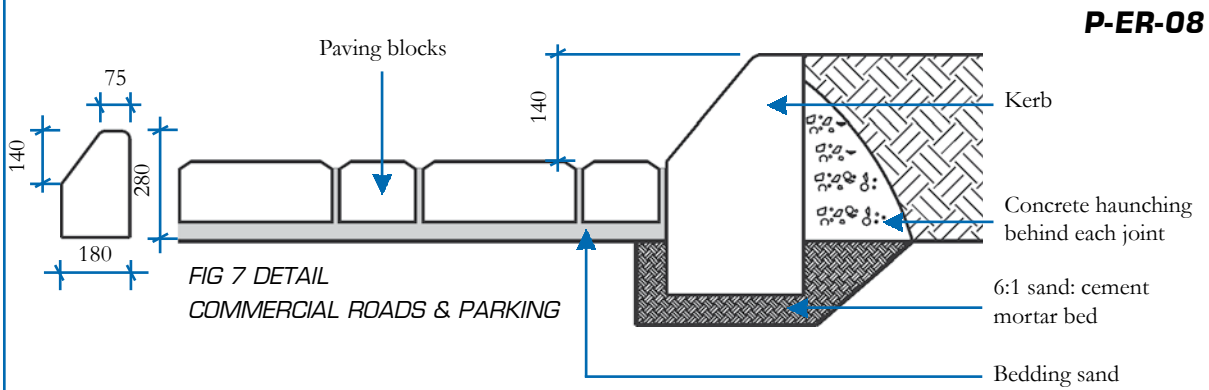
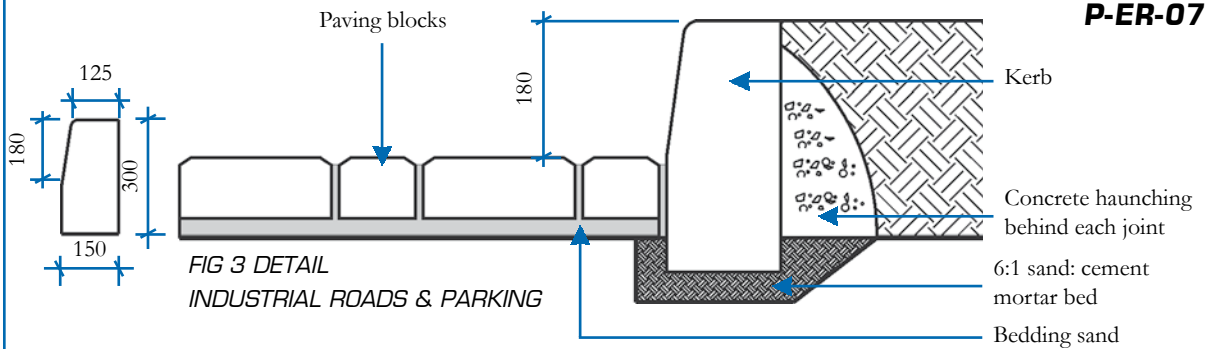

NOTE: Paver thickness 80mm

Precast concrete kerbs should comply with SANS 927-2003

Kerbs are generally supplied in lengths of 0,33m or 1,0m

For extra heavy duty areas continuous concrete haunching should be placed behind kerb / edge restraint



EDGE RESTRAINTS USING PAVERS

P-ER-11

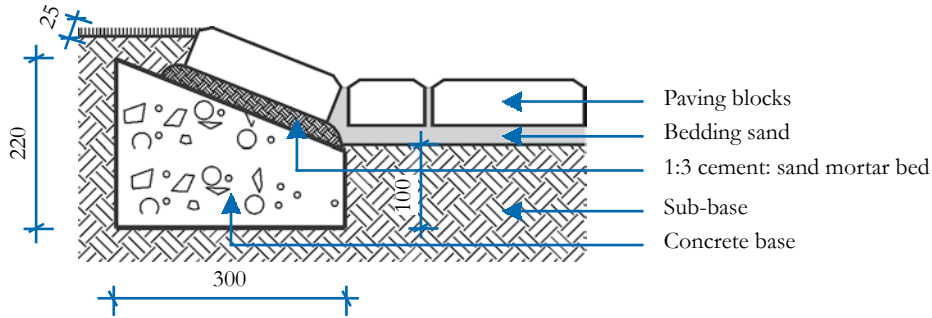

P-ER-12

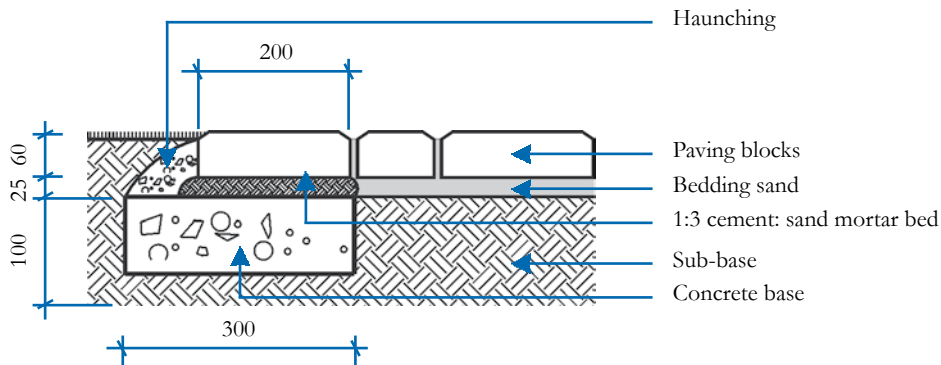

P-ER-13

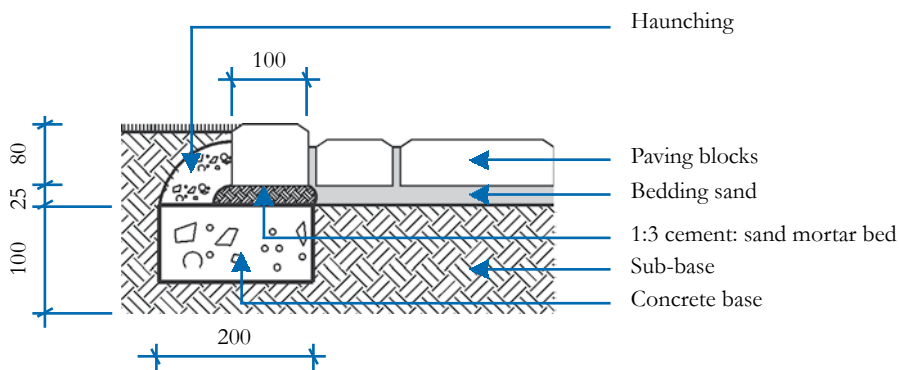

PAVING MEMBERS (SEPTEMBER 2009)

PRODUCER MEMBERS

Bafokeng Concor Technicrete	014 538 0818
Baybrick	035 792 5218
Bosun Brick Midrand	011 310 1176
Brick & Concrete Industries (Namibia)	0026 461 321 3009
Brickcast Industries	031 507 5525
Brickbuild T/A Panda (Botswana)	00267 244 2106
Cape Brick	021 511 2006
C.E.L. Paving Products	021 905 5998
Cast Industries	011 316 2375
Columbia DBL	021 905 1665
Concor Technicrete	011 674 6940
Concor Technicrete P.E.	041 372 2230
Conframat	016 987 3381
Corobrik	031 560 3911
Deranco Paving	041 933 2755
Inca Concrete Products	021 904 1620
Inca Masonry Products	043 745 1215
Infraset Gauteng	011 652 0000
Infraset KZN	031 569 6900
Kopano	016 363 0340
Kwena Concrete Products (Botswana)	0026 739 22850
Mobicast Mossel Bay	044 874 2268
MVA Bricks	012 386 0050
Neat Contech	046 624 3377
Stanger Brick & Tile	032 457 0237
Stone Age Concepts	012 802 1496
Vanstone Precast	012 541 2056
Watson Concrete	011 740 0910
West End Bricks	011 851 1828

ASSOCIATE MEMBERS

<i>Inca (Cape)</i>	<i>021 904 1620</i>
<i>Smartstone</i>	<i>011 310 1161</i>

CONTRACTOR MEMBERS

<i>Daron Construction</i>	<i>034 955 1333</i>
<i>Galaxy Paving</i>	<i>011 815 1175</i>
<i>Mondo Paving & Retaining Walls</i>	<i>011 708 0800</i>
<i>PYW Paving</i>	<i>031 763 5771</i>
<i>Roadstone Civil & Paving</i>	<i>011 683 7080</i>
<i>S A Paving Gauteng</i>	<i>011 483 1350</i>
<i>The Paving Creations</i>	<i>031 765 4083</i>
<i>Vesles Civils</i>	<i>012 662 3030/1</i>
<i>Valcal International</i>	<i>011 867 2471</i>



Block D, Lone Creek, Waterfall Office Park, Bekker Road, Midrand.
PO Box 168 Halfway House 1685
Tel +27 11 805 6742, Fax +27 86 524 9216
e-mail: main.cma@gmail.com website: www.cma.org.za

CONCRETE BLOCK PAVING
Book 1 – Introduction

A walk-over in cost, looks and durability for Concrete Block Paving

CONCRETE BLOCK PAVING
Book 2 – Design Aspects

A walk-over in cost, looks and durability for Concrete Block Paving

CONCRETE BLOCK PAVING
Book 3 – Specification & Installation

A walk-over in cost, looks and durability for Concrete Block Paving

CONCRETE BLOCK PAVING
Book 4 – Site management and laying

A walk-over in cost, looks and durability for Concrete Block Paving

CONCRETE BLOCK PAVING
Book 5 – Training Manual

A walk-over in cost, looks and durability for Concrete Block Paving

CONCRETE BLOCK PAVING
Book 6 – Facilitators Guide

A walk-over in cost, looks and durability for Concrete Block Paving



Block D, Lone Creek, Waterfall Office Park, Bekker Road, Midrand.
 PO Box 168 Halfway House 1685
 Tel +27 11 805 6742, Fax +27 86 524 9216
 e-mail: main.cma@gmail.com website: www.cma.org.za